

A TRIP FROM OBJECT TO IMAGE AND BACK

A. Daskalopoulos, A. Georgopoulos, Ch. Ioannidis, G.N. Makris

National Technical University of Athens
Laboratory of Photogrammetry
e-mail: drag@central.ntua.gr

Commission V, WG V/4

KEY WORDS: Cultural heritage, 3D rendering video, digital orthophotography

ABSTRACT:

While the impressive and ambitious technology of laser scanning is evolving very fast, “traditional” methods are striving to earn the attention they deserve. For certain applications of 3D visualization of objects, classical techniques may still be used with impressive results.

In this paper the steps for the production of a complete 3D digital rendering of the Katholikon of the Dafni Monastery are presented and described in detail. During a strong earthquake two years ago, the Byzantine Monastery of Dafni in Athens suffered severe damages. This particular monument is considered one of the most important specimens of Byzantine art and architecture worldwide and has been included in the World Heritage by UNESCO. The Laboratory of Photogrammetry of NTUA has carried out a complete and thorough survey of the monument. In addition it was decided to produce a 3D digital model based on the aforementioned survey. The 3D rendering made use of all conventional survey measurements and digital photogrammetric products. These products were either raster orthophotographs or vector drawings.

For this effort various types of 3D computer models were considered and their pros and cons assessed and their uses discussed. Wireframes, surface and raster models were considered as the basis of the final product, which would be a 3D virtual reality tour of the church. These models were constructed based on the exploitation of existing detailed survey measurements. This task demanded particular decisions in technical matters, in order for the final product to be as useful and as realistic as possible. The various considerations are thoroughly discussed while their contributions to the final product are taken into account. All material raster required for the final rendering were extracted from the corresponding raster photogrammetric products, i.e. the digital orthophotographs, rectifications and mosaics, using suitable digital image processing techniques.

The final virtual tour was constructed using suitable specialized commercial software. However particular decisions should be made as far as camera settings and orbit, lighting and ambiance specifications were concerned. The resulting video lasts for something less than 5 minutes and gives a pretty good idea of the monument. This end product is compared with the actual video taken from a helicopter and furthermore it is assessed for its usefulness. What has actually been achieved is a virtual trip from the actual object via images and survey measurements to a completely rendered 3D model, which could well replace the real object for many needs.

1. INTRODUCTION

Photogrammetry in principle uses photographic images of the objects of interest as raw data. Complicated techniques have been developed over the years in order to produce specialized visualisations – mostly orthogonal projections, vector or raster – of these objects of interest from these particular images. Lately sophisticated digital techniques have been developed in order to produce three dimensional views of these objects on computer screens, thus satisfying the necessity of the human observer to grasp the environment in 3D. In this way the trip, which started at the real object returns to it via a series of image transformations and representations (Figure 1).

Laser scanning instrumentation and related software is perhaps the future tool for achieving such 3D visualisations. However traditional techniques may still play an important role, as they are able to exploit the detailed work carried out by traditional

photogrammetric techniques, which are characterized by indispensable accuracy and detail qualities.

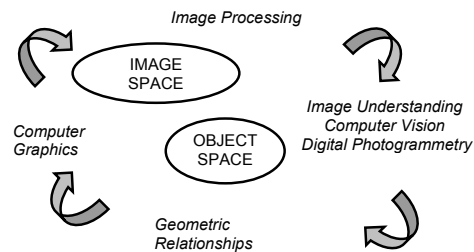

Figure 1: The round trip from object to image

The Dafni Monastery is one of the two remaining today excellent specimens of the culmination of Byzantine architecture (Figure 2). It was built in the 11th century and is situated in the southeastern part of Attica near Athens. The

whole monastery extends on an area of 0.7 hectares and in the centre of that area lies the majestic central church, the Katholikon. In essence it is a cross-domed octagon type of church extending approximately 25x15 m² and 20 m in height. The Monastery is considered to be the Parthenon of the Byzantine era and is internationally protected by UNESCO.

The strong earthquake of 7th September 1999 caused severe damage to the Katholikon and the rest of the buildings of the monastery. The Ministry of Culture immediately decided to take strong measures in order to protect the monument. Before any static or structural interventions a thorough survey of the monument at a general scale of 1:25 was decided. The Laboratory of Photogrammetry of NTUA undertook this task.



Figure 2: The Dafni Monastery

The aim of this project was to exploit the available data in order to produce a three dimensional rendered virtual tour of the monument. In this way the detail and realistic impression of the data from the geometric restitution would contribute to the virtual rendering. At the same time high amount of detail would be included in the final product, in order to give it a high degree of realistic impression.

Similar efforts have been repeatedly reported in recent bibliography (Benning et al. 2001, Cantoni et al. 2001, Gruen et al. 2002, van der Lei 2003). It is evident that there is a growing interest in 3D representations of objects in the technical community. Considerations such as producing realistic video sequences or suitably projecting as much amount of detail as possible have been addressed by all researchers. Hence it was thought to be useful to attempt yet another effort trying to exploit a highly detailed geometric documentation available for the particular monument.

2. DATA AVAILABLE

The project of geometrically documenting the Katholikon of the Dafni Monastery started late in December 1999 and lasted for about two years. The fieldwork covered approximately 30% of this time and for the purposes of the project around 11500 points were measured and 1000 photographs were taken. Digital photogrammetric techniques, mostly performed on a Z/I SSK workstation, were employed for the production of the final products. With the biggest part of the project already finished it was decided to produce a 3D digital model. Apart from the raw data of the survey, the various vector and image products available for that purpose were:

1. Vector drawings of six outside facades, i.e. including the two crosssections of the outer knave, and of the five double longitudinal and five double crosssections through the inside of the monument. In total 26 drawings at a scale of 1:25 and 1:50 were available.
2. Colour photomosaics, i.e. image orthogonal projections corresponding to the 26 drawings of (1) at a scale of 1:25.
3. Vector drawings of horizontal sections at five different levels and a zenith view of the Katholikon at a scale of 1:25 and 1:50.
4. The zenith view of the monument with image projections of the mosaics at a scale of 1:25.
5. Orthogonal image projections of all mosaics at a scale of 1:5.
6. Mathematical developments of the images of all mosaics situated on developable surfaces (i.e. cylinders, cones etc.) at a scale of 1:5. (A. Georgopoulos et al., 2001)
7. Cartographic developments of the images of all mosaics situated on non developable surfaces (i.e. second order surfaces), choosing such a projection in order not to distort the figures depicted on the mosaics and, of course, their aesthetic value. (Valanis, A. 2002).
8. A Data Base built on a GIS philosophy, in order to interrelate every available information for all parts of the monument.

In addition other general helpful data were also available and their use will be indicated later. They included a set of 35mm oblique pictures taken from a helicopter, showing the church from different angles and selected scanned vertical photos taken from the helicopter from a height of approximately 30 meters.

3. BASIC STEPS

For the creation of the 3D virtual tour of the Church, three basic steps were necessary, mainly in order to model the 3D object within the electronic environment. These steps included the creation of a wireframe model, a surface model and a textured model with the final rendering and animation. They were planned and carried out using two commercially available software programs, i.e. AutoCAD 2000[®] from AutoDesk and 3DStudio Max[®].

A wireframe model consists of a series of points – vertices at characteristic points of the monument and the lines in space – and the edges connecting these vertices. Therefore the main task of this step was to define the position, with the help of 3D-coordinates, of the vertices necessary for the formation of the model in a certain coordinate system. Since all of these necessary points were not necessarily measured during the field work of the geometric documentation, it was decided to use the available data in order to virtually determine them. The available data, for this case, consisted of a list of coordinates of control points in the geodetic system and various vector drawings containing the desired edges and the control points. The coordinates of the latter were, however in different coordinate systems, as every projection plane carried its own system for convenience reasons (Daskalopoulos, 2002).

Firstly all geodetically measured control points were imported into the 3D model's unique drawing, with the help of a simple VBA routine, which was developed. Then, the exterior surface of the church was divided into a number of sub-surfaces, defined by suitable groups of vertices. All chosen sub-surfaces were, within reason, assumed parallel to the respective projection planes of the drawings. This assumption meant that the positioning of the vertices relative to the control points was approximately correct taking into account the accuracy of the

rectification method. This methodology was based on the capability to change the user coordinate system (UCS) by defining three points (origin, x-axis, y-axis) within AutoCAD[®]. Working separately on each sub-surface, the same UCS was selected by using the same three control points every time, both in the environment of the drawings and in the 3D model. Since the coordinate systems were the same, all that was needed was to copy the vertices from the 2D drawing and paste them into the 3D model (Figure 3).

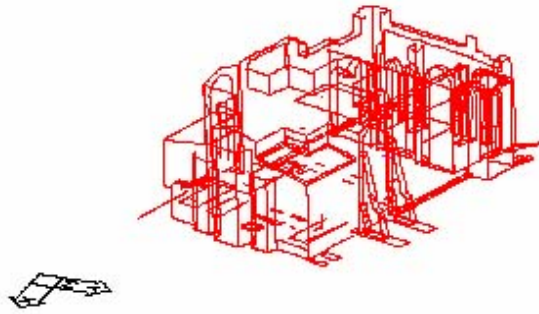

Figure 3: The wireframe model

A major drawback of this methodology was the fact that certain parts of the church, such as the dome, could not be included into the wireframe model, because the critical vertices could not be determined, as the sub-surfaces were not planar and hence could not be considered parallel to any projection plane. Surface models may act as a basis for the creation of the textured model, when the proper surface layering is utilized. Therefore the next step was to transform the wireframe into a surface model. All the surfaces were defined and created separately within AutoCAD, in three different ways, depending on the nature, the shape and the properties of surface. This was carried out with the help of the “pface”, “edge surface” and “region” commands of the software.

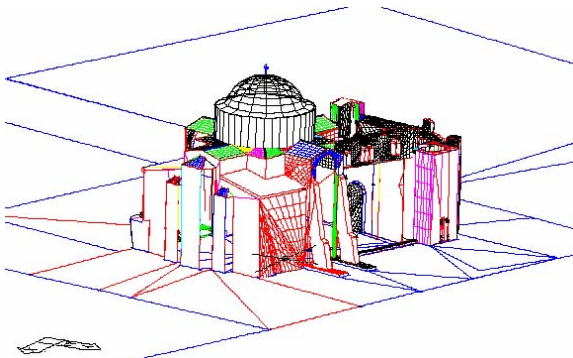

Figure 4: The surface model

In order to complete the model of the exterior of the church, the dome and parts of the roof which were missing had to be separately reconstructed. The surface of the north hemisphere resulted through a surface simulation of a 3D vector drawing of the dome, which was the result of a digital photogrammetric restitution from aerial large scale pictures taken from a helicopter. The same 3D vector drawing was utilized for defining the missing vertices in order to complete the roof section of the model (Figure 4).

The data used for the formation of the wireframe and surface models were all vector drawings of the project of the geometric documentation, the coordinates of the control points and all *.dgn files produced by the digital photogrammetric workstation as byproduct of the rectifications and the orthophotography productions.

All surfaces were exported from AutoCAD to 3D Studio Max for the photorealistic rendering to be carried out. The layering of the surfaces was performed utilizing imaging material from the project of the geometric documentation, suitably processed with the help of Adobe Photoshop v5.0 software. This material was raster orthophotographs of very high resolution and quality, thus setting a very high standard for the quality of the textured model as a whole (Figure 5).



Figure 5: The textured model

4. CONSIDERATIONS FOR THE FINAL RENDERING

In order to complete the project, a virtual tour of the exterior of the church was planned, using the 3D Studio animation tools. To achieve a realistic feeling for the tour, a free 50 mm lens camera was selected for the whole duration of the shots. The path of the camera movement was predefined by selecting a certain number of animation keys which guided the camera around the main parts of the exterior of the Church. Emphasis was given to certain parts of special interest by foreseeing suitable zoomings.

Another important factor to be considered is lighting. It has been found out that the predefined lighting usually proposed by the software does not always guarantee the best result. Hence lighting should be chosen with the object in mind. In the present case four ambient “omnilights” proved to give a better impression than direct sunlight, as one might assume. The aesthetics of the camera shots were finalized by lighting individual angles of the tour, thus giving character and realism where needed.

Last, but not least, is the question of choosing the proper surroundings. It may be easy – and lucrative – to produce a realistic simulation of the ground surface and layer it with suitable aerial images. However, this may lead to excessive results and a more subtle and neutral background should be preferred.

As the frame rate for the desired speed and quality was set to 20 frames per second, thus almost simulating the PAL video system (25fps), the duration of the video resulted to 4 minutes and 30 seconds. The outcome of the selected settings was a rendering of 5401 frames, using an analysis of 640x480 and the

Indeo® Video 5 compression format. Compression was necessary, as the quality and resolution of the images are directly related to the size of the final animation. In order to achieve maximum video quality the frames ought to remain uncompressed and the result would be a file of approximately 2GB. This would mean that the final product would need special storage devices and a lot of free space on the hard disk in order to be reproduced. Moreover uncompressed images lead to unacceptably long rendering procedures. Therefore it was necessary to compress the images using a certain compression format, which would maintain the quality of the final rendering, while keeping the size of the video file to a minimum. The time needed for the rendering to be performed is also dependent on the technical specifications of the computer used.

5. CONCLUDING REMARKS

The produced rendered video, which simulates the reality and ends the round trip started at the object, has been realised using easily accessible instrumentation and low cost commercially available software. This enables the easy and fast production of similar products.

Such products inevitably lack high accuracy for the sake of realism. This is only natural, as they are not yet mature to serve metric purposes. However the fact that accurate orthophotos have been used for the rendering improved the ease of this procedure, as well as the quality of the final 3D model.

Ortho images of high quality were used as texturing material. This fact helped to achieve high quality of the 3D model before the rendering and to reduce the manipulations that were needed when an image was layered over a surface (Figure 6).

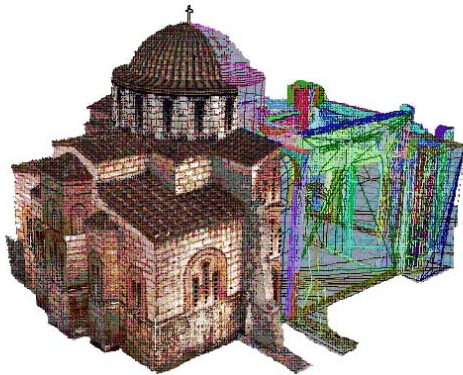

Figure 6: Orthophotos layered on the surface model

During the course of this work several by-products were produced. The wireframe, the surface and the textured model. These models could be used for numerous other purposes, than only for supporting the final rendered video. Such uses could be:

1. Group various elements of the monument (Camara and Latorre, 2001) in order to enable further studies
2. In the same sense project plans may be developed more easily based on these models
3. Furthermore these 3D models may enable the connection to a data base, or even a three-dimensional GIS in order to relate qualitative information to the parts of the monument
4. In case of a ruined monument, the models and the reconstruction may help the users understand the ruins more easily (Ito et al. 2002)

5. Finally these efforts may contribute decisively towards the construction of virtual museums

In this context the video sequence presented in this paper will shortly be completed with a tour of the interior, in order to enable the user to admire the beauty of the unique mosaics of the Byzantine era.

6. REFERENCES

- Benning, W., Effkemann, C., Schwermann, R., 2001. Photogrammetric 3D-Documentation of the Cathedral of Aachen. *Proceedings of XVIII International Symposium of CIPA*, Potsdam, Sep. 18-21 2001, Pp.140-146.
- Camara, L., Lattore, P., 2001. Three-dimensional analytical model obtained by Photogrammetry. Segmentation, operation and applications in the field of architectural restoration. *Proceedings of XVIII International Symposium of CIPA*, Potsdam, Sep. 18-21 2001. Pp. 125-131.
- Cantoni, R., Vassena, G., Lanzi, C., 2001. From the Survey to the 3D animation: The Santa Maria in Solario chapel in Brescia. *Proceedings of XVIII International Symposium of CIPA*, Potsdam, Sep. 18-21 2001. Pp. 256-262.
- Daskalopoulos, Th., 2002. *Digital 3D representation of the Katholikon of the Dafni Monastery*. Diploma thesis, Laboratory of Photogrammetry, School of Rural & Surveying Eng., NTUA, pp. 61 (in Greek).
- A. Georgopoulos, C. Ioannidis, G. Makris, E. Tournas, S. Tapinaki, 2001. Digitally developing works of art. *Proceedings of XVIII International Symposium of CIPA*, Potsdam, Sep. 18-21 2001. Pp.125-131.
- Gruen, A., Remondino, F., Zhang, L., 2002. Reconstruction of the great Buddha of Bamiyan, Afghanistan. *The International Archives of the Photogrammetry, Remote Sensing and Spatial Information Sciences*, Vol. XXXIV, part 5. Proceedings of the ISPRS Commission V Symposium "Close Range Imaging, Long Range Vision", Sep. 2-6 2002, Corfu, Greece, pp. 363-368.
- Ito, J., Iwabuchi, K., 2002. Reconstruction of Ancient Olympia in 3D computer graphics. A landscape analysis of classical site. *The International Archives of the Photogrammetry, Remote Sensing and Spatial Information Sciences*, Vol. XXXIV, part 5. Proceedings of the ISPRS Commission V Symposium "Close Range Imaging, Long Range Vision", Sep. 2-6 2002, Corfu, Greece, pp. 385-389.
- Van der Lei, K., 2003. Toposcopy. A new close range Photogrammetric system. *Geoinformatics*, Vol. 6, March 2003, pp. 16-19.
- Valanis, A., 2002. Fitting, portrayal and mapping for the production of 2nd order photomosaics. *The International Archives of the Photogrammetry, Remote Sensing and Spatial Information Sciences*, Vol. XXXIV, part 5. Proceedings of the ISPRS Commission V Symposium "Close Range Imaging, Long Range Vision", Sep. 2-6 2002, Corfu, Greece, pp. 463-467.