

## GENERALIZATION OF 3D BUILDING DATA BASED ON SCALE-SPACES

Andrea Forberg and Helmut Mayer

Institute for Photogrammetry and Cartography, Bundeswehr University Munich, 85577 Neubiberg, Germany  
andrea.forberg@unibw-muenchen.de

Commission IV, WG IV/3

**KEY WORDS:** Three-dimensional Generalization, Simplification, Building Model, Automation, Visualization, Feature Analysis

**ABSTRACT:**

For an interactive visualization of three dimensional (3D) city models a Level of Detail representation is extremely useful to avoid unnecessary computations. Differently detailed models of the same object are displayed depending on the distance of the object. This implies that less detailed models have to be generated from complex models (generalization). In this paper an approach for the automation of 3D generalization especially for building data is presented. It uses the formally well-defined scale-space theory which includes morphology and curvature space. Practical investigations for the scale-space operations making use of the geometry kernel ACIS 3D Geometric Modeler show good results for morphology. For curvature space important preparations concerning the distinction between convex and concave object parts have been carried out. Tasks still to be performed include the coherent modeling and the implementation of continuous curvature space, the combination of morphology and curvature space, and the rectification of angles.

### 1 INTRODUCTION

The performance of the interactive visualization of three dimensional (3D) polyhedral data depends on the number of polygons that have to be rendered. To improve the speed, often the Level of Detail (LOD) concept is used where objects that are far away are represented with less detail than close ones (cf. Fig.1).

Many approaches for automatic polygon-reduction exist in computer graphics and computational geometry. A good survey on approaches for surface simplification is given in (Heckbert and Garland 1997). Further examples for automatic LOD generation can be found, e.g., in (Varshney et al. 1995) and (Schmalstieg 1996). An approach close to our approach dealing with computer aided design (CAD) objects is presented in (Ribelles et al. 2001).

Unfortunately, most of these approaches do not consider the specific properties of an object type such as right angles of urban objects. Opposed to this, model generalization of cartography takes into account these properties, but there is hardly any work on 3D building data. Basics about automatic generalization can be found in (Mackaness et al. 1997; Meng 1997; Staufenbiel 1973, and Weibel and Jones 1998).

In this paper we base the automatic creation of less detailed models, i.e., model-generalization, on the formally well-defined scale-space theory. The basic idea is a multiscale representation in which for a coarser scale, fine scale information with high frequency is eliminated.

On one hand, we modify the scale-spaces “morphology” and “curvature space” to deal with polyhedral, mostly rectangular building data. On the other hand, we extend the generalization of building data to 3D.

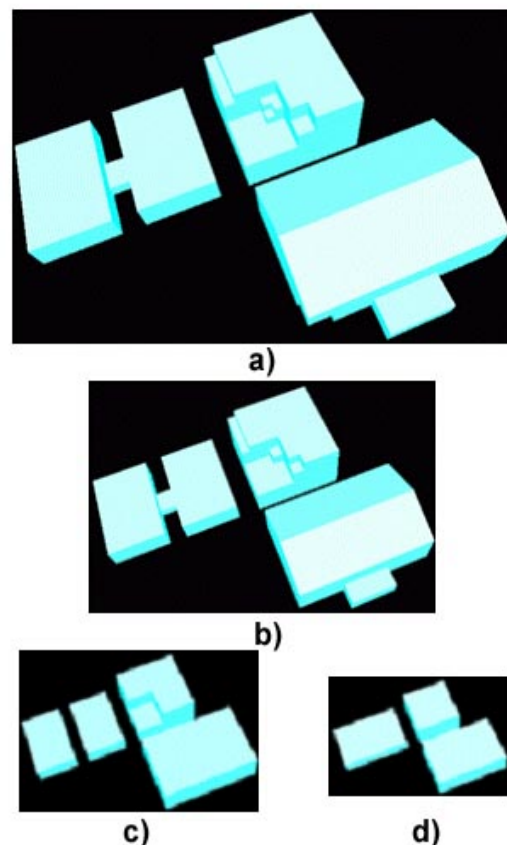

Figure 1. Different Levels of Detail (LOD)

## 2 SCALE-SPACES AND SCALE-SPACE EVENTS

### 2.1 Scale-Spaces

One basic scale-space is the linear scale-space, where causality, isotropy, and homogeneity are combined. This scale-space family continuously smooths the image function and satisfies the so called “diffusion equation” for which the convolution with the Gaussian Kernel  $g: \mathbf{R}^2 \times \mathbf{R}_+ \setminus \{0\} \rightarrow \mathbf{R}$  is the solution for an infinite domain (Koenderink 1984):

$$g_\sigma(x, y) = \frac{1}{2\pi\sigma^2} e^{-\frac{x^2+y^2}{2\sigma^2}} \quad (1)$$

Another scale-space is mathematical morphology (Serra 1982). It is based on the two basic operations erosion and dilation and the two combined operations opening and closing, here defined for grey-scale images:

$$\begin{aligned} \text{Erosion} \quad (f \ominus g)(\bar{x}) &= \inf_{\bar{x} \in G} (f(\bar{x} + \bar{x}') - g(\bar{x})) \\ \text{Dilation} \quad (f \oplus g)(\bar{x}) &= \sup_{\bar{x} \in G} (f(\bar{x} - \bar{x}') + g(\bar{x})) \\ \text{Opening} \quad (f \circ g)(\bar{x}) &= ((f \ominus g) \oplus g)(\bar{x}) \\ \text{Closing} \quad (f \bullet g)(\bar{x}) &= ((f \oplus g) \ominus g)(\bar{x}) \end{aligned} \quad (2)$$

Because building data usually consists mostly of straight segments, which also have to be preserved, erosion and dilation are realized by shifting the complete segments inward or outward, respectively.

By combining morphology and linear scale-space, the reaction-diffusion-space is obtained. The reaction part comprises erosion and dilation, whereas the diffusion part, also termed curvature space, is for a small-scale parameter equivalent to the linear scale space. For a large-scale parameter it diverges in a way that only parts with high curvature are eliminated.

### 2.2 Scale-Space Events

When applying a scale-space to an image, certain events can happen. In Figure 2 a part with too small extent is eliminated and in Figure 3 gaps are filled by erosion and dilation, respectively.

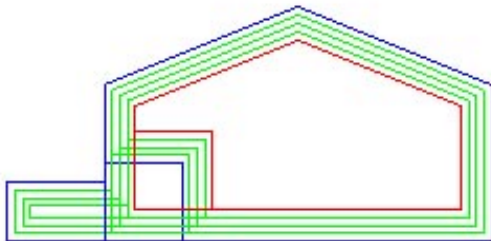

Figure 2. Erosion: blue – original object; green – incremental steps; red – object after erosion; annex is eliminated.

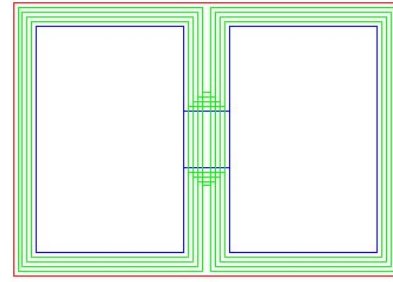

Figure 3. Dilation: blue – original object; green – incremental steps; red – object after dilation; gap between two building parts is filled.

There are two things happening in parallel while transforming the objects from fine scale to coarse scale. Firstly, the information is reduced by means of scale-space events. Secondly, the elimination of object parts such as an annex (cf. Fig.2) or the closing of gaps (cf. Fig.3) often results in a simplification or abstraction of an object. This abstraction capability makes the scale-spaces well suited for generalization.

### 2.3 Opening and Closing in 3D - Internal as well as External Events

Dilation and erosion are in 3D synonymous with moving all facets of the polyhedral building data in the direction of the normals. Instead of erosion and dilation opening and closing are used to reset the object to its original range of size. For small objects such as an annex inward moving facets collide while opening the object and hereby the annex is eliminated (cf. Fig.4). This is called an “internal event”, because it only affects topologically neighboring facets. By employing the scale-space in small steps, i.e., incrementally, events can be handled by simple basic operations.

So-called “external events” emerge when topologically non-neighboring facets of one or more buildings touch or overlap while opening and closing. For instance, a building consists of two big blocks connected by a narrow block in fine scale (cf. Fig.5). Two buildings are created after eliminating the narrow block while opening. On yet a coarser scale, the two big blocks are merged while closing, resulting again in one building (cf. Fig.6).

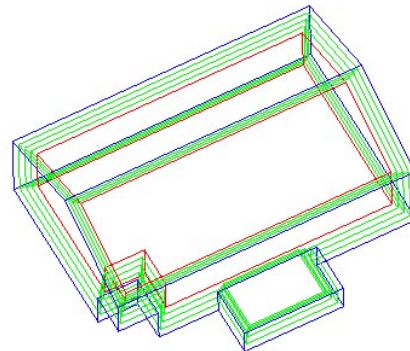

Figure 4. Elimination of the annex while erosion in 3D: blue – original object; green – incremental steps; red – object after erosion.

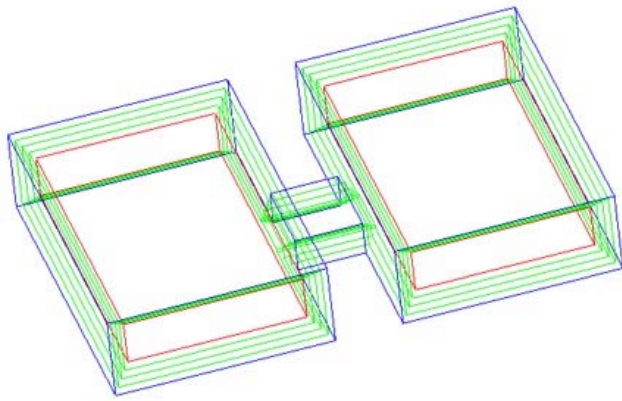

Figure 5. Splitting of two object parts while erosion in 3D: blue – original object; green – incremental steps; red – object after erosion

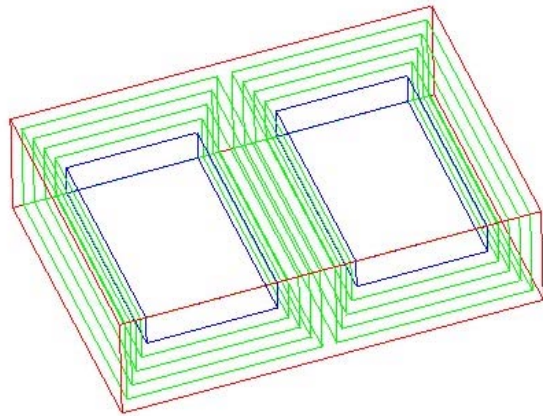

Figure 6. Melting of two objects while dilation in 3D: blue – original object; green – incremental steps; red – object after dilation

#### 2.4 Discrete and Continuous Curvature Space

While morphology provides the only means to aggregate or split objects, it cannot be used to eliminate step-structures and inward or outward pointing boxes (cf. Fig.1a) upper centre). This is the strong point of curvature space.

In curvature space the facets are moved in a way that steps and boxes are eliminated. This is shown in two dimensions (2D) in Figure 7 for Z- and L-structures. Curvature space in 3D can be treated in a discrete or a continuous way.

In discrete curvature space only specific facets under a certain size are shifted. E.g., for Z-shapes the two long segments are moved in opposite directions in a way that the short segment becomes even shorter. For more than one short segment all segments are shifted inward or outward at the same time (cf. Fig.7). In 3D the procedure is similar. Only the facets belonging to the step or the box which has to be eliminated are shifted inward or outward.

In contrast to this, in continuous curvature space all facets are moved, but the speed of the movement is weighted by the area of the facets and by the length of the corresponding edges. The different properties of discrete and continuous curvature space are shown in Table 1 (Mayer 1998).

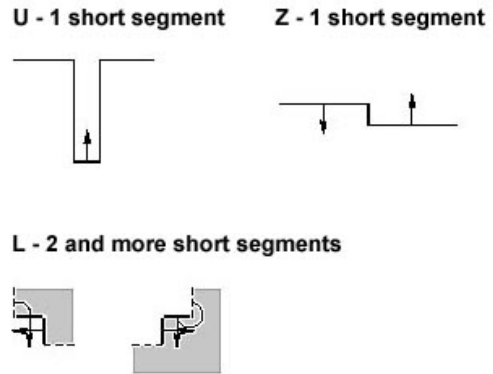

Figure 7. Movement of the facets to eliminate U-, Z-, and L-structures

	Discrete Curvature Space	Continuous Curvature Space
Generality	Depends on threshold	General
Movement	Convex facets are fixed	All facets move with different speeds
Weighting	Area	Length of segments (concave only) + area; (e.g.: length <sup>2</sup> * area)

Table 1. Basic properties of Discrete and Continuous Curvature Space

In order to decide in what direction facets have to be moved, the determination of elements like steps and outward and inward going boxes is necessary for both curvature spaces. The differentiating feature is convexity or concavity, respectively. For the detection of concave segments (step-structures and inward going boxes) different approaches exist:

In (Mayer 1998) the relation of the normals which depend directly on the 2D polygons of the neighboring facets are used to control the movement of the facets. The concave segments are determined by comparing the orientation of three subsequent points of the ordered point-list of the 2D polygon with the orientation of the whole polygon. When the orientations are different, the points define two concave segments (cf. Fig.8).

The problem of this approach in 3D lies in the decision if a structure goes inward or outward. Especially with nested structures as seen in Figure 10 this becomes an intricate problem.

Therefore in this paper a new approach to determine concave segments which can deal with this problem is proposed. It investigates the interior angles between neighboring facets and determines, if points created by extending segments are in- or outside of the polyhedron. The approach is described in detail in section 3.4.

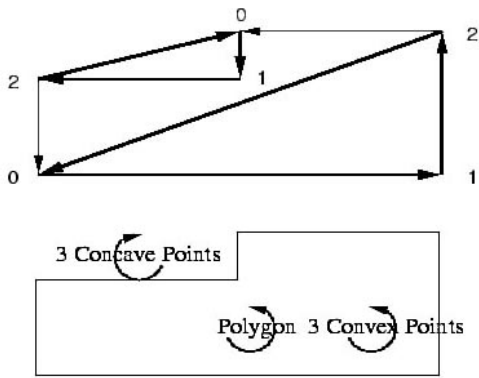

Figure 8. Concave segments have a different orientation from that of the polygon.

### 3 PRACTICAL INVESTIGATIONS

#### 3.1 ACIS 3D Geometric Modeller and VRML

The prove of concept was done in (Mayer 1998) based on CGAL (Computational Geometry Algorithm Library, [www.cgal.org](http://www.cgal.org)) with a fixed sequence of opening, closing, and curvature space. This led to acceptable results, but great effort was needed to change the topology of the polyhedra after the scale-space events.

Therefore, it was decided to use a more suitable tool, particularly the ACIS 3D Geometric Modeler (Spatial Corp., [www.spatial.com](http://www.spatial.com)) that offers a more general solution for 3D topology. Functions that can directly be used for the erosion and dilation as well as for the change of the angles between single facets of the object already exist. The latter function can be used to handle non-orthogonal structures. Short descriptions of the functions mainly used are given in the following sections. As input format VRML (Virtual Reality Modeling Language) as a common file format for interactive 3D models is used. It offers the possibility to build test objects in a fast and simple way and many programs provide the possibility to export their own formats to VRML. To construct the ACIS objects out of the VRML models a converter was implemented.

Until now in ACIS only separate tests for morphology and discrete curvature space have been made. The investigations concerning the ACIS functionalities are not yet finished, but the main tasks are already functional.

#### 3.2 Morphology

For morphology all facets need to be moved simultaneously inward or outward. In ACIS this is termed offsetting. The function `api_offset_body` works for all kinds of objects, but for the task of generalization it is only well suitable for orthogonal structures. Inclined structures disappear far too slow, especially when the inclination is low (cf. Fig.9 lower right).

For perpendicular structures, small segments are eliminated by incrementally offsetting the whole object until ACIS reports a change in topology.

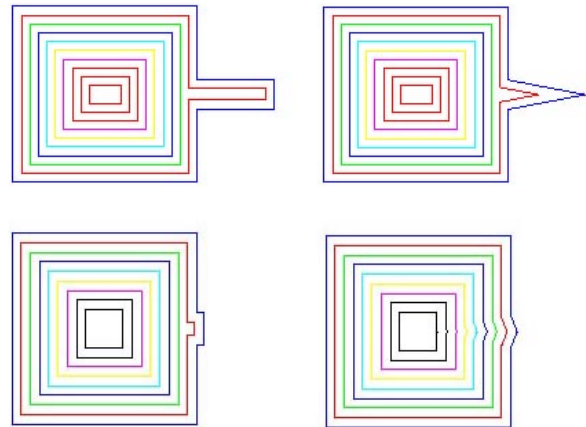

Figure 9. Erosion, seen from above: inclined structures especially with a low inclination (cf. lower right), disappear slow compared to orthogonal structures.

#### 3.3 Curvature Space

Compared to morphology for curvature space it is not only yet sometimes unclear how to move the facets (cf. section 2.4), but it is also more complex to implement it with ACIS. Using morphology the whole object is handled at once. All facets are moved the same distance in or opposite to the direction of the normals.

Contrary to this, in discrete curvature space only a selected number of facets is shifted and in continuous curvature space all facets are shifted with various distances. ACIS provides the functions `api_offset_faces` and `api_offset_faces_specific`. The first one shifts a set of facets for a fixed distance and is therefore suited best for discrete curvature space. The latter moves each facet individually and can therefore be used for continuous curvature space.

Until now mainly the discrete curvature space operations were tested in ACIS. The first task is to decide which facets have to be moved. For this, and in order to obtain the sign for the movement of a particular facet, one has to know, if a vertex is concave or convex.

Yet, the determination of the convexity and concavity of vertices is only the basic problem. The concave and convex parts can construct rather complicated nested structures. The remainder of this section deals with the determination of the hierarchy of the concave and the convex structures.

#### 3.4 Concave and Convex Parts

First attempts to determine the convexity of a vertex were made by computing the interior angles between the facets which are neighbors to the vertex. If all interior angles at a vertex are  $90^\circ$ , the vertex describes a perpendicular corner which is convex, if they are  $270^\circ$ , it is concave (cf. Fig.10).

A more general solution is made by extending the coedges belonging to, i.e., ending at a vertex (cf. Fig.11 and 12). An edge according to ACIS is adjacent to two facets which results in two coedges with different directions, each associated with a loop in one of the two facets

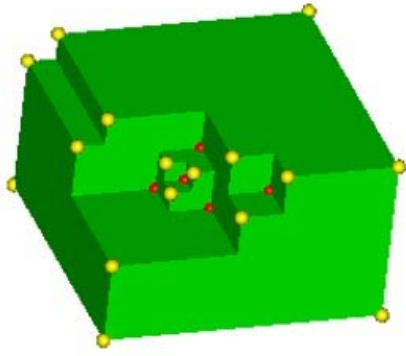

Figure 10. Convex (yellow) and concave (red) vertices

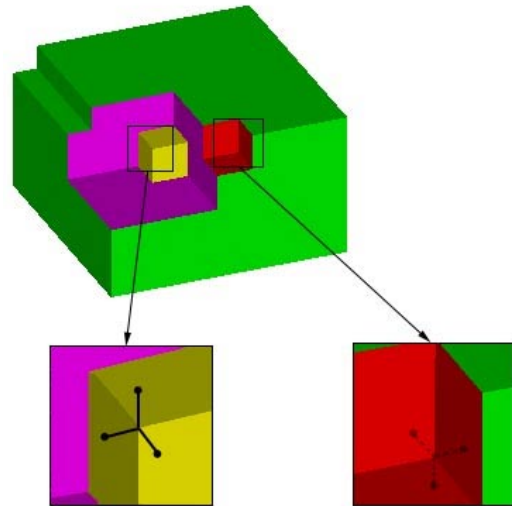

Figure 12. Coedge-extension to distinguish convex and concave vertices: If all ends of the extended edges at a vertex lie outside, it is a convex vertex (left), if they lie inside, it is a concave vertex (right)

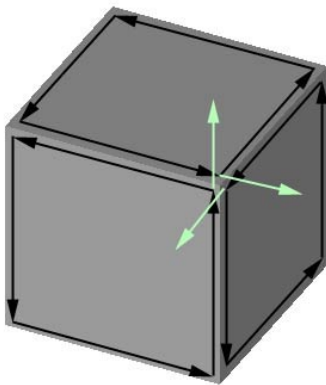

Figure 11. Coedge structure (black: directions of the coedges; green: extensions of the coedges)

The coedges are only very slightly extended (linear equation) and the new endpoint is tested for its relation to the object itself by the ACIS function `api_point_in_body`. Possible relations are inside, outside, or on the boundary of the object. If all extended points belonging to a vertex lie inside the object, the vertex describes a concave corner, if they are all outside of the object, it is convex (cf. Fig.12).

Unfortunately, the determination of concave and convex vertices is not sufficient for the decision which facets have to be moved outward or inward, respectively. If an object consists of nested structures as seen in Figure 10, additionally different kinds of concave structures have to be distinguished.

The five concave vertices in Figure 10 (represented as red spheres) belong to different types of box structures. To determine if a box points inward or outward, the facets which are neighbors of the obtained concave vertices are investigated. If all related facets do not contain any other concave vertex, this is a fully concave, inward pointing box without any other object part contained (cf. Fig.13, red facets). Else, it is part of a nested structure (magenta and yellow facets).

Next the concave structures which are higher in the hierarchy (magenta) have to be distinguished from the convex structures they include (yellow). The number of concave vertices for each of the facets is known. If a facet contains only one concave vertex, it is convex (yellow). If there are two of them, the facet is concave (magenta).

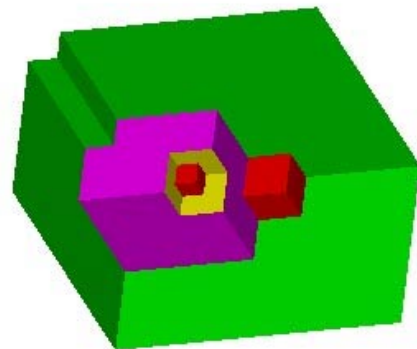

Figure 13. Determination of different types of outward or inward going boxes

After the determination of the three types of facets, the sign of the movement is clear. While the concave facets (red and magenta) have to be moved outward, the convex facets (yellow) have to be moved inward. In Figure 12, e.g., we have eliminated the smallest of the inward pointing boxes in the centre of Figure 13.

What is left to determine is the distance for the movement. At the moment it is, e.g., investigated if an incremental offsetting of the specific facets is suited best, or if the offset distance has to be fixed by the length of the shortest edge contained in a set of facets. The latter is due to the fact that the ACIS functions only produce a cleaned topology if facets are coplanar.

#### 4 CONCLUSIONS AND OUTLOOK

An approach for the generalization of orthogonal building structures using the scale spaces “morphology” and “discrete

curvature space” was introduced. The test implementation was done in ACIS and shows good results for morphology where annexes can be removed or objects can be split or aggregated. For the implementation of the discrete curvature space operations which can handle step-structures and outward and inward going boxes important preparatory work has been done. It can be automatically determined which facets have to be moved and in which direction of the normal. The way of movement, i.e., incrementally or fixed distances, still has to be investigated. Another step is to realize the continuous curvature space, where the movement of a facet depends on, e.g., the area of the facet and the length of the corresponding edges. A suitable function for the specific offset in ACIS already exists. Though, the theory is not yet totally consistent. For practical generalization morphology and curvature space need to be combined. One way is to determine a fixed sequence of both operations, which suits best for most of the common building structures. Another way which is investigated would be to combine both scale-spaces conceptually. As the work at the moment is restricted to orthogonal models, additionally rectification is necessary. Contrary to the test models, real data in many instances will not be orthogonal. In ACIS exists the function `api_edge_taper_faces` for changing the angles between the facets. An algorithm for automatically detecting and correcting slightly distorted angles has to be developed. The code to derive the interior angles between facets mentioned in section 3.4 could be used as starting point. Though, intricate practical but also theoretical problems have to be solved. In 3D it is not sufficient to only change the angle between two facets because all other angles are affected by the change and are also changed even if they should be preserved. The result could be a much more skewed model which must be avoided. In the future also the main directions of the building may have to be taken into account. Finally, the scale-space operations are to be tested on real data instead of the simulated test objects.

## REFERENCES

- Heckbert, P. and Garland, M. (1997): Survey of Polygonal Surface Simplification Algorithms. Multiresolution Surface Modeling Course SIGGRAPH '97
- Koenderink, J. (1984): The Structure of Images. *Biological Cybernetics* **50**, pp. 363-370.
- Mackaness, W., Weibel, R., and Buttenfield, B., (1997): Report of the 1997 ICA Workshop on Map Generalization. Publication of the ICA Working Group on Map Generalization, <http://www.geo.unizh.ch/ICA/>, Gävle, Sweden.
- Mayer, H. (1998): Three Dimensional Generalization of Buildings Based on Scale-Spaces. Technical Report, Chair for Photogrammetry and Remote Sensing, Technische Universität München, Germany.
- Meng, L., (1997): Automatic Generalization of Geographic Data. Technical Report, VBB Viak, Stockholm, Sweden.
- Ribelles, J., Heckbert, P., Garland, M., Stahovich, T., and Srivastava, V. (2001): Finding and Removing Features from Polyhedra. Proceedings of DETC'01, ASME Design Engineering Technical Conferences, Pittsburgh, Pennsylvania, USA.
- Schmalstieg, D. (1996): LODESTAR: An Octree-Based Level of Detail Generator for VRML, Technical Report, Institute of Computer Graphics, Visualization and Animation Group, Vienna University of Technology.
- Serra, J. (1982): *Image Analysis and Mathematical Morphology*. Academic Press, London, Great Britain.
- Staufenbiel, W. (1973): Zur Automation der Generalisierung topographischer Karten mit besonderer Berücksichtigung großmaßstäblicher Gebäudedarstellungen. Vol. 51, Wissenschaftliche Arbeiten der Fachrichtung Vermessungswesen der Universität Hannover, Hannover, Germany.
- Varshney, A., Agarwal, P. Brooks, F., Wright, W., and Weber, H. (1995): Generating Levels of Detail for Large-Scale Polygonal Models, Technical Report, CS-1995-20, Department of Computer Science, Duke University, USA.
- Weibel, R. and Jones, C. (1998): Computational Perspectives on Map Generalization. *GeoInformatica* **2**(4): pp. 307-314.