

GA-BASED PATH FINDING FOR PUBLIC TRANSPORT NETWORK

C. Jun

Dept. of Geoinformatics, University of Seoul, Seoul, Korea - cmjun@uos.ac.kr

KEY WORDS: Public Transportation, GA, GIS, Route Selection, Shortest Path

ABSTRACT:

As the applied fields of GIS are expanded to the transportation, developing internet-based applications for transportation information is getting attention increasingly. Most applications developed so far are primarily focused on guidance systems for privately-owned cars. Although some recent ones are devoted to public transportation systems, they show limitations in dealing with the following aspects: (i) people may change transportation means not only within the same type but also among different modes such as between buses and subways, and (ii) the system should take into account the time taken in transfer from one mode to the other. This study suggest the framework for developing a public transportation guidance system that generates optimized paths in the transportation network of mixed means including buses, subways and other modes. For this study, the Genetic Algorithms are used to find the best routes that take into account transfer time and other service-time constraints.

1. INTRODUCTION

Many recent applications for transportation are devoted to car-navigation systems that provide the user with the shortest or fastest path between the source and the destination where he or she wants to travel. Although a few systems found among commercial GIS sites were developed for public transportation, there are some negative views concerning their limitations in considering transfers between modes and time constraints in transfer areas. As the results, they often fail to provide practical solutions to user's requests. With these issues in mind, the study suggests an alternative methodology for building a route guidance system in the network of public transportation. The study employed the Genetic Algorithms (GAs) to find the minimum-time paths considering different combinations of transportation modes. The GAs is one of heuristic search methods. Like the *k*-shortest path algorithm (Lewer, 1972), since the GA-based methods generate multiple "better" paths, the user can have more choices from where he or she can select based on different preferences such as total amount of fares, convenience, preferred routes and so on.

2. TIME-CONSTRAINTS PROBLEM

If the network is composed of different kinds of vehicles, such as scheduled trains, subways, flights, or buses, and transfers between them take place, waiting time for the next departure should be taken into account. The time-constraints problems have been dealt with as the common form of time window problems, which assume a node in the network has a list of pre-specified departure times and require that departure from a node be allowed only at one of these departure times. In those nodes where transfers take place, the departure time is constrained for each available mode and comparison among these different departure times needs to be performed in order to explore the minimum time path.

Figure 1 illustrates the time constraints in a portion of the network. If a traveler reaches the stop S-1 at minute 4, he or she will be able to come to S-2 at minute 6. Then, the next available vehicle will be at minute 10, which means there is a waiting period of 4 minutes. If he or she wants to take the

Mode C, the waiting time will be 5 minutes. On the other hand, if one comes to S-1 at minute 14, he or she will be able to take the Mode C after waiting 1 minute. But the transfer to the Mode B is not possible because the time when he or she reaches S-2 exceeds the latest departure time, minute 15. Consequently, the path that passes the node 3 will be impossible. As such, a time window defines the earliest time and the latest time that the node is available.

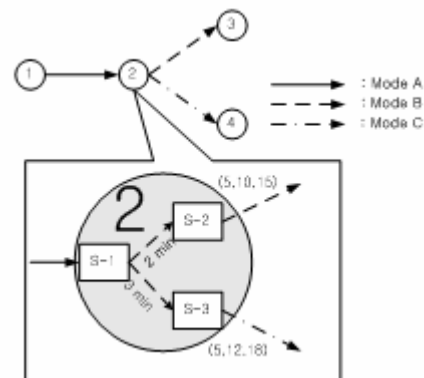

Figure 1. Time-constraints problem at a transfer area

3. GENETIC ALGORITHMS

Genetic algorithms (GAs) use the terms borrowed from natural genetics. In GAs, candidate solutions to a problem are expressed using individuals called strings or chromosomes which are arrays of characters (Michalewicz 1999). Here, the characters composing a chromosome are called genes.

A global search process is performed on a certain population of chromosomes by gradually updating the population. Search processes are conditioned by two objectives: exploiting the best solutions and exploring the search space. The process for

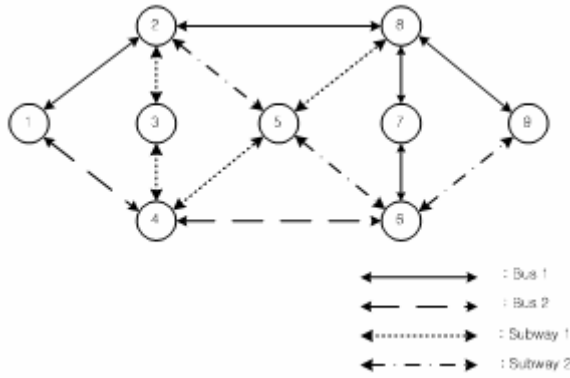

Figure 2. An example of multi-modal network

creating the first population is called the initialization. The updating processes of the population, the creation of successive generations, are done using so-called the genetic-operators: crossover and mutation. These genetic operators alter the composition of children of parent chromosomes. The search process is continued until it reaches the maximum number of generations while searching for “better” solutions that are evaluated by the “fitness” function. Therefore, the fitness function along with some parameters such as population size and probabilities of applying genetic operators are required in advance. Figure 2 shows a simple example of a network where different types of vehicles are present. In nodes such as 3 or 7, transfer does not happen. But the rest nodes allow the traveler to transfer to another mode.

Representation A chromosome can be represented by linking the nodes from the source to the destination. If the source is Node 1 and the destination is the Node 9, a chromosome is an array of nodes that include Node 1 at the first position and Node 9 at the last.

Initialization The initial population of chromosomes is created according to the preset population size. All nodes for each chromosome are initialized randomly as the following manner;

- C1 = (1, 2, 8, 9)
- C2 = (1, 4, 5, 6, 9)
- C3 = (1, 2, 5, 6, 7, 8, 9)
- ...

Evaluation The evaluation function or the fitness function plays the role of the environment, rating potential solutions in terms of their fitness. Evaluation function *eval* for node vectors C can be set as the total time taken from the origin to the destination as follows;

$$eval(C) = gene_travel_time(x),$$

Selection Selection is a preparatory process that is needed for updating the current population. In order to preserve good chromosomes, some of them are reproduced in the next generation instead of participating in the mutation or crossover. This way, we can prevent those elite chromosomes from being deleted in the process. Selection process also includes the process that selects the parent chromosomes for crossover or mutation, which is described in the following section.

Genetic Operators Some members in the initial population undergo alteration by means of two genetic operators: crossover and mutation. Crossover combines the features of two parent chromosomes to form two similar children by swapping corre-

sponding segment of the parents. For example, if the parents are C₂ and C₃, then a common node (e.g. Node 5) can be selected and the portions of chromosomes after this node are crossed generating new children:

$$\begin{array}{l}
 C_2 = (1, 4, \underline{5}, 6, 9) \\
 C_3 = (1, 2, \underline{5}, 6, 7, 8, 9)
 \end{array}
 \rightarrow
 \begin{array}{l}
 C_2' = (1, 4, \underline{5}, 6, 7, 8, 9) \\
 C_3' = (1, 2, \underline{5}, 6, 9)
 \end{array}$$

Mutation arbitrarily alters the positions of one or more genes. In the transportation example, just exchanging a certain gene can generate a chromosome having disconnected link of nodes. Thus, we can modify the mutation process to fit this problem. If a certain gene is selected as the target of mutation, it can be thought of the temporary origin and then a portion of chromosome is created that reaches the destination. Assume C₂ has been selected and third gene, Node 5 has been selected as the mutation. Then, Node 5 becomes the temporary origin yielding a chromosome from this node to Node 9. After the mutation, new C₂ can be created as

$$C_2 = (1, 4, \underline{5}, 2, 8, 7, 6, 9) \rightarrow C_2' = (1, 4, \underline{5}, 2, 8, 7, 6, 9)$$

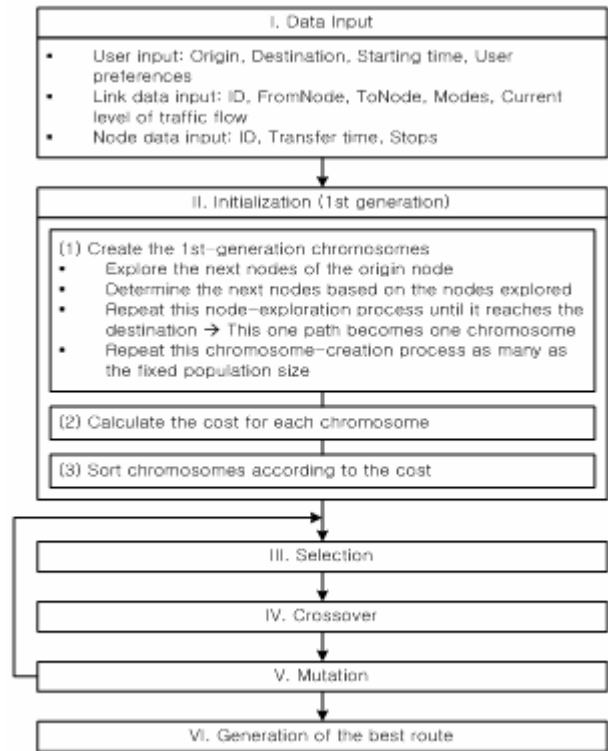

Figure 3. Flow of the GA process

As seen from this, mutation can either increase or decrease the value of selected chromosomes. Figure 3 summarizes the flow of the GA process.

4. DATA STRUCTURE IN THE GIS

Describing the public transportation system that has multi-modes using a GIS requires the following considerations:

- Bus stops or subway stops can be located in those spots other than crosses.

- Topological relationships exist between nodes and links. Nodes are the stops or stations where vehicle stops for passengers and the links are the routes between them.
- In case of buses, more than one bus line may share a stop.
- A transfer area can be defined as the area where more than one stops are located closely enough for the passengers can move between the stops on foot.

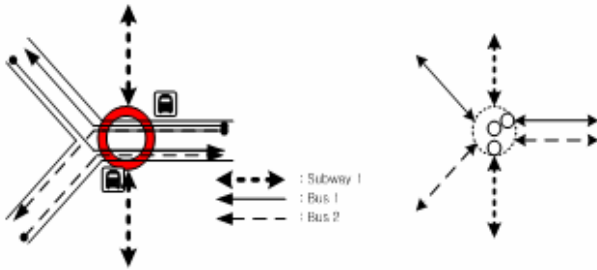

Figure 4. Representation of a transfer area

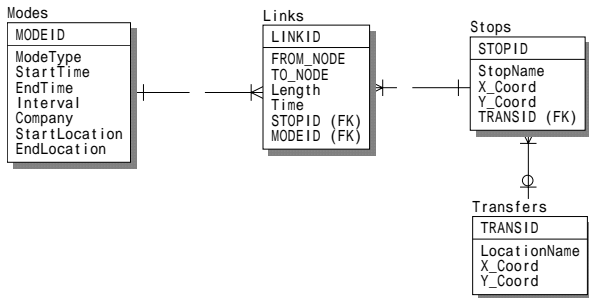

Figure 5. ERD for GIS Data Construction

Figure 4 shows a simplified example of a transfer area. Although Figure 2 modeled transfer areas using single nodes, each of them actually contains more than one station. When constructing GIS data, these relationships must be implemented along with other topological relationships between nodes and links. Figure 5 shows a portion of the GIS data structure that embodies important features of relationships between modes, links, stops and transfers.

5. IMPLEMENTING THE SEARCH IN THE GIS

To test the search process using GAs, an imaginary data have been constructed as figure 6. The data contain multi-modes including buses and subways. Some of the nodes are belonged to transfer areas based on the distance of the stops and whether the stops are used by different modes or not. Figure 7 illustrates how a chromosome is created and displayed on the screen. The

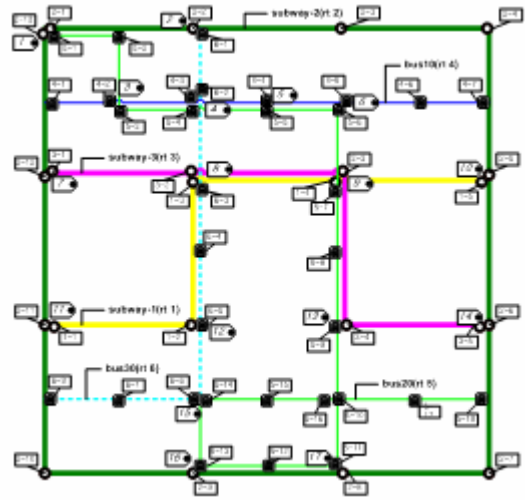
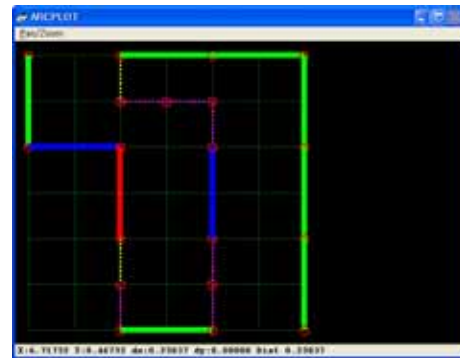

Figure 6. Modeling a network of different modes



```

=====
Printing the results...

Departure: 12:30
Arrival: 13:58
Total time taken: 1:28 (88 min)
Total length run: 26000 meters
Total times transferred: 10
Total Fare: 6100 won
Total time walked: 24 minuts
Service availability: .true.
=====

```

Figure 7. Illustration of chromosome-creation process

user is first prompted to enter the source and the destination. Then, the user needs to provide the starting time. As an example, assume the user clicked the upper-left corner and the lower-right corner of the network as the source and the destination respectively and entered 12:30PM as the starting time. Other values such as service time or intervals of vehicles and parameters needed in GA-process are all assumed and coded into the program. Some resulting values are shown in the below of Figure 6.

6. CONCLUDING REMARKS

The study discussed the problem of finding the minimum-cost path in the network of multi-modes of public transportation. To make the search process more realistic, time-constraints in the transfer areas must be considered. This makes public transportation problem more complex than the problem of

single-mode network or owner-car network. Genetic algorithms aim at such complex problems. The study used the GA-based approaches in finding the minimum total time path. In order to use GIS data, some reorganizations and relationships centering on the transfer areas were necessary. In this preliminary study, an imbedded script language called AML was used to automate the whole process because the language contains many built-in functions that handle the coverage-format data. This resulted in somewhat slow performance than expected. However, as mentioned earlier, GAs are a good example where parallel processing can be applied. Since processes for creating chromosomes are independent each other, the speed can be significantly increased by using parallel processing. As of now, the author is developing a public transportation guidance system on the Web-based interface using real data.

ACKNOWLEDGEMENT

This study has been supported by the Korea Science & Engineering Foundation. (R01-2002-000-00328-0)

REFERENCES

- Chang, I-S., 2000. A Hybrid Model of A* Search and Genetic Algorithms for ATIS under Multiple Objective Environment, *Journal of the Korean Institute of Industrial Engineers*, 26(4), pp. 421-430.
- Chen. Y. L. and K. Tang, 1998. Minimum Time Paths in a Network with Mixed Time Constraints, *Computers and Operations Research*, 25, pp. 793-805.
- Desrochers, M. and F. Soumis, 1988. A Reoptimization Algorithm for the Shortest Path Problem with Time Windows, *European Journal of Operational Research*, 35, pp. 242-254.
- Lawler, E. L., 1972. A procedure for computing the K best solutions to discrete optimization problems and its application to the shortest path problem, *Management Science* 18, pp. 401-405.
- Michalewicz, Z., 1994. Genetic Algorithm + Data Structure = Evolution Programs, Springer-Verlag.