

# THAILAND EARTH OBSERVATION SYSTEM : MISSION AND PRODUCTS

M. Kaewmanee<sup>a</sup>, T. Choomnoommanee<sup>a</sup>, R. Fraisse<sup>b</sup>

<sup>a</sup> Geo-Infomatics and Space Technology Development Agency (GISTDA), 10900, Bangkok, Thailand - (morakotk, tanapati)[@gistda.or.th](mailto:gistda.or.th)

<sup>b</sup> EADS Astrium, 31402, Toulouse, France – [renaud.fraisse@astrium.eads.net](mailto:renaud.fraisse@astrium.eads.net)

## Commission I, WG I/6

**KEY WORDS:** Small Satellite, Fusion, Image, Push -broom, THEOS, High Resolution, Optical sensor

### ABSTRACT:

Thailand Earth Observation System (THEOS) Development Program was begun in July 2004. The program is developed by Geo-Infomatics and Space Technology Development Agency (Public Organization) (GISTDA) under the Ministry of Science and Technology, with European Aeronautic Defence and Space Company – Astrium (EADS Astrium SAS), in France, as a prime contractor. It consists of design, development, test, launch, and commissioning phases of THEOS satellite, as well as integration with associated control and data exploitation ground facilities. The aim of this paper is to present the characteristics of THEOS program which consists of the system architecture, satellite architecture, its associated ground facilities (Control Ground Segment and Image Ground Segment) and their products.

THEOS satellite is a compact and agile satellite with a mass of 750 kilograms and a power consumption of 800 Watts. It has two push-broom scanning optical instruments, providing worldwide imagery in Panchromatic and Multispectral modes, covering the Visible and Near Infrared spectrum. The Panchromatic instrument has a resolution of 2 metres and a swath width of 22 kilometres. The Multispectral instrument has a resolution of 15 metres and a swath width of 90 kilometres. The satellite will be launched into a sun-synchronous low earth orbit in July 2007 and will have a design lifetime of at least 5 years.

THEOS CGS (Control Ground Segment) will be established in Thailand to provide commands and control of the satellite. The satellite can be programmed either to downlink image data in real-time imaging or to read from the onboard memory and transmit image data recorded earlier during the same or previous orbital revolutions. Facilities will be provided at this station to accommodate the reception and processing of the data. THEOS system routine operational activities are organised on a daily basis with flexibility enabling to urgent requests.

Data downlinked from the instrument will be transmitted to THEOS IGS (Image Ground Segment). The role of THEOS IGS is to provide value added products from THEOS images corresponding to end users' needs. It is equipped with a 13m X band antenna and RF electronics. Its hardware and software enable the automatic processing of the transmitted image telemetry (at 120 Mbps) up to level 2A. The 4 working stations of the Image Exploitation Facility provide high level tools to generate added value and precision product.

## 1. INTRODUCTION

After many years of using remote-sensing data from foreign satellite systems, Thailand has decided to have its own earth observation satellite system for rapid and sustainable country development. Thailand Earth Observation System (THEOS) Development Program was then begun in July 2004. The program is developed by Geo-Infomatics and Space Technology Development Agency (Public Organization) (GISTDA) under the Ministry of Science and Technology, with European Aeronautic Defence and Space Company – Astrium (EADS Astrium SAS), in France, as a prime contractor. THEOS system, which is fully owned by Royal Thai Government, will be operated by GISTDA.

## 2. ARCHITECTURE OF THEOS SYSTEM

THEOS system is a stand-alone earth observation system. The architecture of THEOS system has been developed in order to satisfy needs and requirements from GISTDA, Ministry of Science and Technology, as well as other relevant Ministries and imagery users in Thailand. These requirements include resolutions, swath width, coverage area, revisit frequency, as well as image quality and applications.

THEOS system comprises of the following main constituents, as shown in Figure 1.

- THEOS Satellite (Space Segment)
- Ground Facilities (Ground Segment)
  - Control Ground Segment (CGS)
  - Image Ground Segment (IGS)

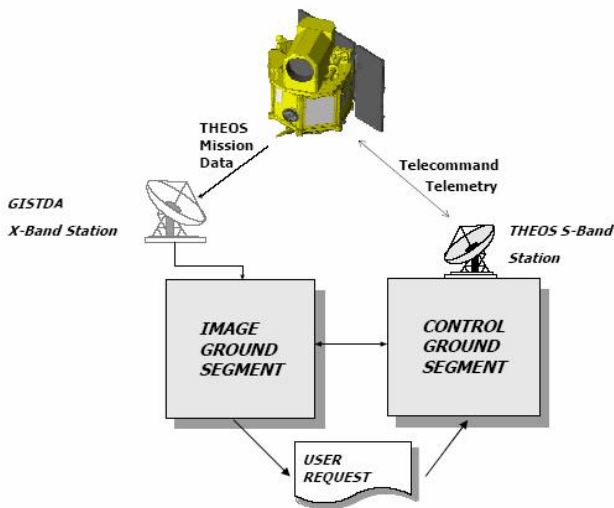

Figure 1. Architecture of THEOS system

### 3. PERFORMANCE OF THEOS SATELLITE

The payloads of THEOS Satellite are Panchromatic and Multispectral push-broom scanning optical instruments. The radiometric and spatial performances of the instruments have been optimised between resolutions and swath width in order to satisfy imagery application requirements in Thailand.

The spectral range of each imagery band of Panchromatic and Multispectral instruments together with their spatial performance is shown in Table 1 and Figure 2. THEOS satellite has a tilting capability of up to  $\pm 50^\circ$ , although some high accuracy applications might limit this to  $\pm 30^\circ$ . It can be tilted both in fore and aft, as well as east and west direction of satellite ground track.

	PAN	MS
<b>Spectral bands and resolution</b>	panchromatic (2 m)	4 multispectral (15 m)
<b>Spectral ranges (<math>\mu\text{m}</math>)</b>	P: 0.45 - 0.90	B1(blue):0.45-0.52 B2(green):0.53-0.6 B3(red):0.62-0.69 B4(NIR):0.77-0.90
<b>Imaging swath</b>	22 km	90 km
<b>Signal to Noise Ratio</b>	> 90	> 100
<b>Image dynamics</b>	8 bits among 12 bits	
<b>Absolute localisation accuracy (level 2A)</b>	< 300 m	
<b>Off-nadir viewing</b>	$\pm 50^\circ$ (roll and pitch)	

Table 1. Spectral Band and Spatial Performance of THEOS Satellite

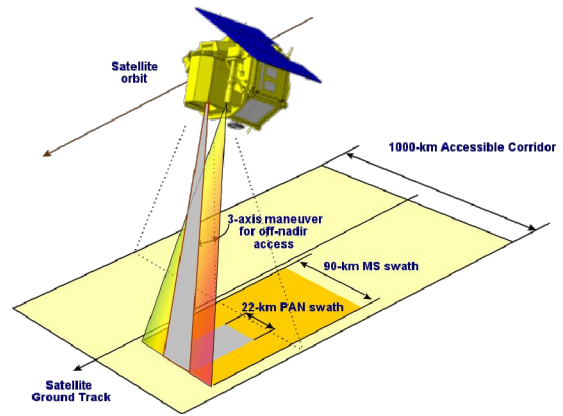

Figure 2. Spatial Performance of THEOS Satellite

The orbit of THEOS satellite will have parameters as shown in Table 2. With this orbit and its tilting capability, THEOS satellite will have worldwide imagery area, as well as short revisit and access time, as shown in Figure 3 and Figure 4. It can be seen from Figure 4 that if the satellite is tilted to its maximum capacity of  $50^\circ$ , accessible corridor will already cover 90% of the whole earth surface within 1 day.

Parameter	Value
Orbit Type	Circular sun-synchronous low earth orbit
Altitude	822 km
Number of Orbits per Day	14+5/26 orbits per day
Local Equator	10:00 am
Orbital Period	101 minutes
Orbit Inclination	$98.7^\circ$
Orbit Cycle	26 days (369 orbits)
Distance Between Passes (at Equator)	108 km (Between 2 closest passes) 2800 km (Between 2 consecutive passes)
Coverage Area	All earth surface
Visibility Area	Radius of more than 2000 km From ground station (at $5^\circ$ elevation angle)
Access time	2 days with $50^\circ$ tilting angle 5 days with $30^\circ$ tilting angle

Table 2. THEOS Satellite orbit parameters

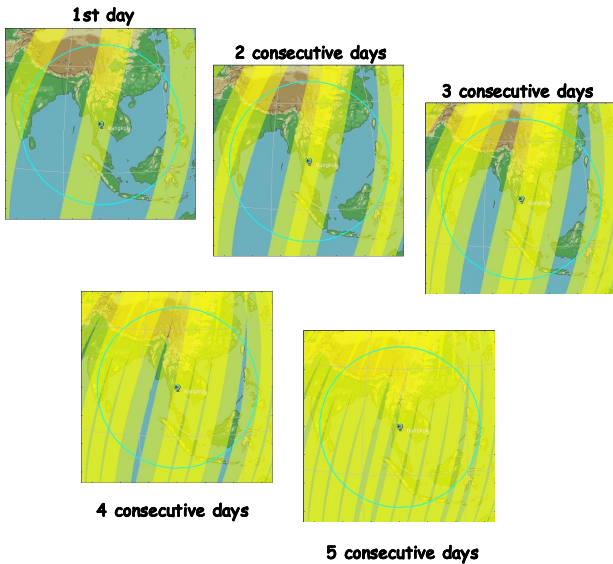

Figure 3. Accessible Corridor Covered in 5 Days (with 30° tilting angle)

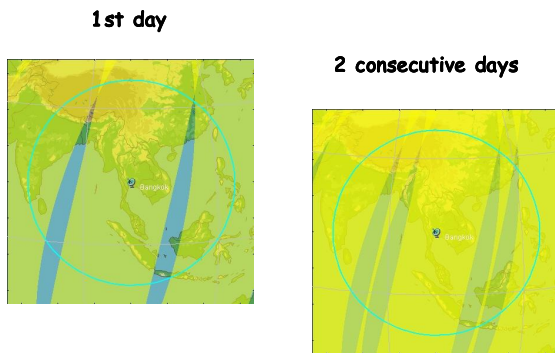

Figure 4. Accessible Corridor Covered in 2 Days (with 50° tilting angle)

#### 4. ARCHITECTURE OF THEOS SATELLITE

THEOS satellite consists of two main parts, the optical instrument payload and the platform or bus. That platform is based on AstroSat 500 Bus, which has already been designed and developed by EADS Astrium. All the technologies used in THEOS Satellite are space qualified and have been used in other earth observation programs. This can ensure the minimum risk and guarantee the success of the THEOS mission.

THEOS platform consists of the following subsystems.

- On-board management unit
- Image processing unit
- S-band unit for telemetry and telecommand link
- X-band unit for payload data downlink
- Power distribution and regulation unit
- Thermal control system for both the payload and the platform
- Attitude and orbit control system, which has the following sensors and actuators

- Magnetometer, sun sensor, star sensor, gyroscope, and GPS receiver
- Magnetotorquers, reaction wheels and thrusters.

The specifications of THEOS satellite are summarised in Table 3.

Parameter	Value
Total Mass	750 kg
Size	2.1 m x 2.1 m x 2.4 m
Power Consumption	800 W
Nominal Life Time	> 5 Years
Fuel and Capacity	Hydrazine 80 kg
Payload Data Recorder	50 Gbit solid-state memory
Data Processing	Compression ratio of 2.8 or 3.7
Data Downlink Rate	120 Mbit/s (X-band)
Orbit Determination	GPS
Payload	Panchromatic and Multispectral cameras
Satellite Ground Speed	6.6 km/s

Table 3. Specifications of THEOS Satellite

The AstroSat 500 Bus has a hexagonal shape with a length of 1.5 metre on each side, as shown in Figure 5. The size is determined by the area for equipment installation on each panel as well as to be compatible with small launcher fairing with a diameter of 2 metres.

The top of the platform is attached to payload interface plate. This is where optical instrument payload as well as star sensor and gyroscope are mounted, for high accuracy pointing. At the bottom of the platform are four reaction wheels and four thrusters for attitude and orbit control, respectively. The propulsion module and fuel tank are located in the middle of the platform. All other subsystem units are mounted on each panel for the reasons of balance, thermal control, electrical and mechanical aspects, as well as flexibility of integration and test.

The 2 cameras of the THEOS Optical Payload image the earth with CCD at the focal plane of high precision optics. The Panchromatic instrument structure (primary mirror and focal plane) is made in Silicon Carbide (SiC) which ensures a very

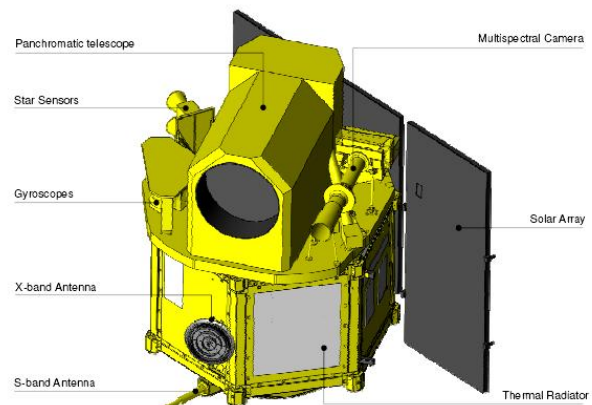

Figure 5. THEOS Satellite Flight Configuration

good thermo-elastic stability. The multispectral instrument is a dioptric camera with 4 filters. At the focal plane of each instrument are located the linear arrays of Charge Coupled Devices (CCD) which transform the focalised radiance from ground into electronic signal. The imaging principle is the "pushbroom scanning" concept. Each line of the image is electronically scanned and successive lines are imaged thanks to the motion of the line of sight on the ground.

### 5. THEOS IN ORBIT

After the satellite is released from launcher, solar array will be automatically deployed, acquisition sequence will be automatically activated, and first contact with ground will be made. In Normal Mode, the satellite will be kept in the sun pointing configuration during sun light, and optical instrument will be in stand-by mode. When imaging is required, the satellite will be earth pointed with some tilting in order to access the target area. During eclipse, the satellite will be kept in earth pointing configuration for telecommand uplink as well as telemetry and data downlink.

When the satellite is switched to Acquisition and Safe Hold Mode from Normal Mode due to anomaly, satellite will be reinitialised and recovered. During this time, the satellite will have to be able to rely on its autonomy, without any ground contact. This is achieved by switching off all unnecessary equipments to ensure sufficient power, and use only the most reliable equipments, which are sun sensor, magnetometer, magnetotorquers, and reaction wheels in order to ensure sun pointing configuration during sun light for power generation, and earth pointing configuration during eclipse for ground contact.

### 6. THEOS GROUND SEGMENT

THEOS ground segment consists of 2 main segments namely

1. Control Ground Segment (CGS) :
2. Image Ground Segment (IGS)

**Control Ground Segment** provides commands and control of the satellite. It is composed of three main elements : The Flight Dynamics Centre, the Satellite Control Centre and the Mission Planning Centre. The satellite operational activities are routinely organized on a daily basis with flexibility enabling to accommodate requests from users.

**Image Ground Segment** receives downlinked data from the satellite via 13 m X- Band station. It processes and archives transmitted data through image processing chain to produce value added products corresponding to user's requests. Its hardware and software enables the automatic processing of transmitted image telemetry (at 120 Mbps) up to Level 2A which can be done through DPF(Data Processing Facility). In addition, IEF (Image Exploitation Facility) has its role dedicated to produce value added products such as orthoimages, DEM, spatio map. Figure 6 shows overall THEOS Ground segment architecture.

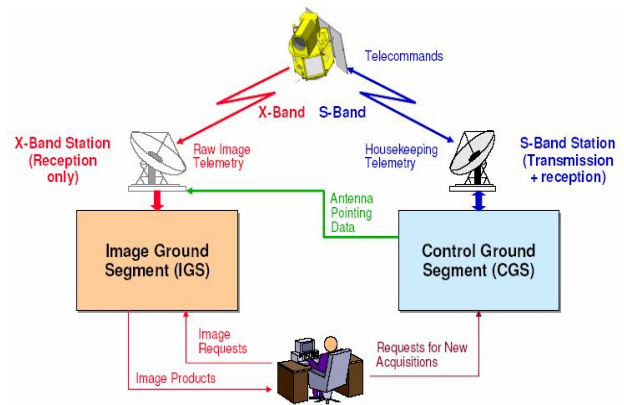
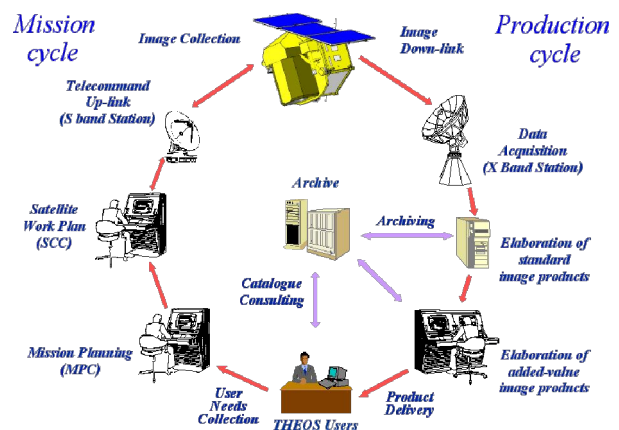

Figure 6. THEOS Ground Segment Architecture

THEOS ground segment will be located in Bangkok Thailand. The reception visibility cone covers main part of Asia: South East Asian countries, Mainland China and East Asian countries with 2000 km radius, as shown in Figure 7. Therefore, this enables Asian users to have a direct and quick access to THEOS images.



Figure 7. THEOS Visibility radius covers large part of Asia



## 6.1 Image Acquisition

THEOS image acquisition is performed on user's requests. It involves the following procedures.

**6.1.1 Product Ordering :** THEOS Product Ordering System is divided into 2 cycles. Firstly, customers can order and purchase imagery directly if it is available in the archive through IGS. Secondly, they can order new imagery which requires scheduling and tasking of THEOS satellite which is done via CGS Mission Planning Centre and elaboration with

Figure 8. THEOS Ground Segment Operation Cycle

IGS. This can be done according to standard user's request form which details of image specification are defined such as image location, product level, time allocation, image acquisition requirement etc.

Once the product request is received by MPC, a daily satellite work plan is generated taking into account availability of satellite resources and the feasibility of imaging requests. If all conditions are met, the work plan is uplinked to the satellite and complete the cycle through IGS where the image is downlinked and processed to process the product. The whole THEOS Ground Segment Operation cycle can be seen in Figure 8.

### 6.1.2 THEOS Programming and Satellite Tasking :

THEOS programming is done on a daily basis with 24 hours before the overpass of the last night visibility. The optimal work plan has been elaborated considering priority criteria such as acquisition priority, imaging mode, due date, together with availability of satellite resources. In nominal mode, the finalized daily work plan is done and ready before 5 pm, however the scheduled program can be edited by the system operator 1 hour prior the pass in case of an urgency. The generated work plan is then submitted to SCC (Satellite Control Center) for TC preparation and uploaded to THEOS Satellite via S-Band station. The on board software recognizes the TC and computes the satellite maneuvers in order to perform image acquisition. Once the successful TC transmission is acknowledged by THEOS satellite, telemetry is sent down to the ground station through S-band station.

### 6.1.3 Onboard Data Storage and Image Telemetry

**Downlink:** The image telemetry is downlinked in two ways depending on whether or not the satellite is within the visibility circle from the receiving station.

- If it is within range of the receiving station, the satellite can be programmed to downlink image data in real time or to read from on board memory (50 Gbits) and transmit image data recorded earlier during the same orbital revolution.
- If it is not within range of the receiving station, the programmed acquisitions are executed and the image data stored on the onboard memory.

The telemetry data is transmitted to the ground station via X-Band antenna, at a rate of 120 Mbps following on-board compression using "Regulated JPEG" (same technique as for SPOT 5, which achieves a high quality compression with a compression ratio around 3 to 4).

The downlinked data stream follows the CCSDS standard. It includes ancillary data which encompasses instrument parameters (gain level, detector temperature, etc.) and satellite parameters (time, position, attitude) which are necessary for the further ground processing of image data.

**6.1.4 Auxiliary Data and Catalogue Generation :** The transmitted Telemetry data is ingested and decrypted and processed. In order to increase image product accuracy, auxiliary data, satellite parameters and image auxiliary data corresponding to image data, are used. Catalogue images are generated to evaluate cloud cover in semi-automatic or manual mode and to determine if the imagery fulfils the user's request.

## 6.2 Data Processing and Image Products

THEOS image data can be processed by 2 IGS entities, DPF and IEF which produces standard products and value added products, respectively.

### 6.2.1 THEOS Standard Products :

**Level 1A :** radiometric correction for each detector ( synchro loss and defective pixels, non uniformities, MS registration)

**Level 2A :** Geometrical correction of systematic effects such as panoramic effect, Earth curvature and rotation. Internal distortions of the image are corrected for measuring distances, angles and surface areas. A terrain model indicating elevation above the reference ellipsoid is also used. In addition, the projection is done in a standard cartographic projection (UTM WGS84) without the use of ground control points..

**Pan sharpening :** The PAN sharpened image is the fusion of image information coming from the PAN high resolution and from the MS color image giving a high resolution MS image as seen in Figure 9. It is generated by a dedicated algorithm adapted for THEOS.



Figure 9. THEOS Pan Sharpened image

### 6.2.2 THEOS Value Added Products :

**Level 2B :** The product is corrected for radiometric and geometrical distortion with ground control points derived on maps or from GPS measurement taken in the field. The image is corrected for a mean elevation in the projection and a standard map frame. This product is used when deformations due to relief are not significant i.e. flat ground.

**Digital Terrain Model:** can be derived from semi automatic correlation of THEOS stereopairs containing uniform grid of terrain elevation values over the area of interest.

### 6.3 Archiving and Delivering

The quality of each final image product is checked before delivery to the customers. All end products are compatible with the DIMAP and GEOTIFF standards. All images are archived not only for the purpose of customer's request but for potential future requested area in order to optimize the collection rate of satellite passes which will be engaged in the future.

### 6.4 Acquisition Capabilities,

As designed, the ground station configuration is capable of handling 960 minutes THEOS access time per month. With daily production performance, the system can generate more than 40 products in less than 6 hours.

**6.4.1 Imaging Mode :** THEOS satellite is able to provide many type of acquisition modes :

- *Multi-target mode*, where the satellite can acquire many targets within the satellite ground track, plus imaging in fore and aft stereoscopic mode if required.
- *Covering or Strip imaging mode*, the satellite can image strips of various length (up to 4000 km length).

Due to its high agility, THEOS satellite can image various targets during a pass, as illustrated in Figure 10. The satellite is capable of imaging up to 30° from nadir position. In case of an urgent access, imaging can be done up to 50° from nadir.

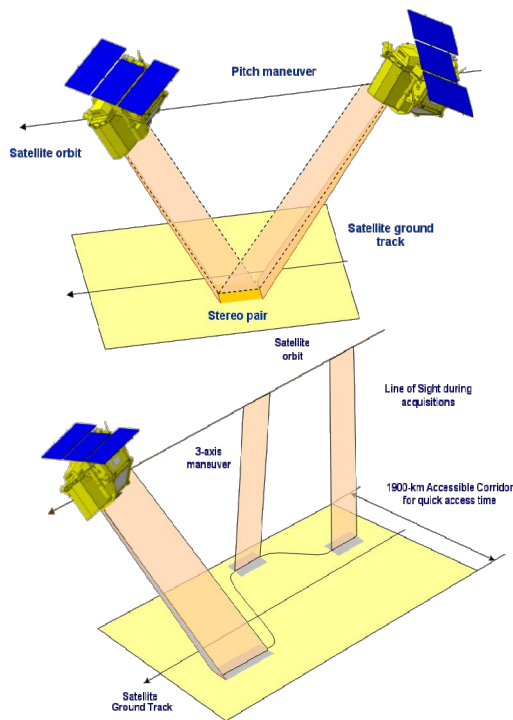

Figure 10. THEOS Operations Capabilities

**6.4.2 Repeat Viewing Capabilities:** THEOS oblique viewing capability enables it to image any area within 1000 km swath width ( for 30° roll). Oblique viewing can be used to increase the viewing frequency for a given point during a given cycle. However, the frequency can vary depending on latitude. For example, over Thailand, a given area can be imaged 9 times during the same 26 day cycle i.e. 126 times a year with an average of 3 days, with an interval visit ranging maximum from 5 day to the minimum of 1 day.

**6.4.3 Stereoscopic Capabilities:** Stereo pairs can be used for relief perception and digital elevation modeling. THEOS can provide 2 different modes of stereo pairs imaging.

- The programming of two images of the same area on the ground acquired at different roll viewing angles on successive satellite passes or
- The pitch agility allows to acquire a stereo pair in the same pass at less than 5 minutes delay.

THEOS is a high agility satellite therefore it enables low B/H stereoscopic acquisition with attractive length for example more than 300 km. length of stereoscopic coverage can be imaged from the same track with a B/H of 0.84 ( like SPOT5/HRS). The time to maneuver satellite to perform pitch stereo pairs up to 40° is less than 60 seconds including tranquilization.

**6.4.4 Mean Acquisition capabilities:** Thanks to its high agility, high image storage and data downlink capabilities, THEOS can acquire images coverage up to 88,000 km<sup>2</sup> and 360,000 km<sup>2</sup> per orbit for PAN and MS respectively.

## 6. CONCLUSION

The use of data from satellite remote sensing system to monitor and support the exploitation of resources and other disciplines requires high resolution data with large swath width and frequent revisit time. Thailand Earth Observation System (THEOS) Development Program is designed to fulfil all these needs. THEOS system comprises of THEOS satellite as well as associated control and data exploitation ground facilities.

THEOS satellite with its two pushbroom scanning optical instruments, providing combines the high resolution imaging (Panchromatic instrument) with a large swath width (Multispectral instrument). The satellite high agility provides frequent revisit capability and high reactivity.

THEOS system includes an operational ground segment with direct access to THEOS data and high quality image products. The visibility circle of the station covers main part of Asia and enables Asian users to have direct and quick access to THEOS.

Image acquisition and data processing is highly operational with 4 passes per day, over the station providing up to 32 minutes of imaging per day. The image ground segment can produce level 2A products in less than 30 minutes.

In addition, the launch of THEOS satellite is already stimulating scientific research and the development of new techniques for agricultural and new application fields.

## REFERENCES

Fortescue, P., Stark, J., Swinerd, G., 2003, Spacecraft Systems Engineering (Third Edition), Wiley

GISTDA and EADS Astrium, THEOS User Handbook

Larson, W. J., Wertz, J. R., 1999, Space Mission Analysis and Design (Second Edition), Microcosm, Inc.

P. Kongseri, et al., 2005, Thailand Earth Observation System (THEOS) Development Program

Technical proposal document for THEOS System under the memorandum of understanding between Thai and French government on space technology and applications

THEOS Development Documentation, EADS