

QUALITY EVALUATION OF GENERALIZATION ALGORITHMS

Yevgeniya Filippovska, Volker Walter, Dieter Fritsch

Institute for Photogrammetry (ifp), Universitaet Stuttgart, Germany
Geschwister-Scholl-Strasse 24D, 70174 Stuttgart
- firstname.lastname@ifp.uni-stuttgart.de

Commission II, WG-II-7

KEY WORDS: Data Quality, Generalization, Building

ABSTRACT:

Cartographic maps can only contain a certain amount of information. If the information density is too high, the map becomes hard to comprehend for a human viewer. A common solution for this problem is to simplify the geometry of the map objects or even to delete some of them. In this cartographic generalization, the rate of simplification depends on the scale of the map. However, to preserve the readability, the simplification follows certain rules. These rules must not necessarily minimize a geometric error, but might rather accept a certain geometric deviation to better suit the cognitive capabilities of humans. That means that for one object many different generalized objects are possible. In this paper we will discuss how generalized objects can be evaluated with quality measures in order to decide which generalization is the best one for a specific application.

1. INTRODUCTION

The generation of maps in different scales is one of the most significant tasks in cartography. Being far away from trivial, generalization becomes more specific in the GIS environment. For this reason two kinds of generalization can be distinguished: (1) cartographic generalization and (2) model-oriented generalization. Cartographic generalization concerns only the visualization of geospatial information and occurs at the graphic level. Thus, the readability of a map has a preference for positional accuracy. Model-oriented generalization takes place within the scope of the internal representation of a map and pursues reduction of the information density in a database. This modification can also be considered as a pre-processing for cartographic generalization (Cheng, 2001; Dettori and Puppo, 1998; Han-Sze-Chuen et al., 2002). The focus of this work is on cartographic generalization and on the evaluation of geometric distortions of single polygonal objects, which are produced in consequence of it.

It should be noted, that for paper maps the geometrical accuracy is restricted by the drawing accuracy and the scale. Thus, the scale value of paper maps is an aggregated parameter which characterizes the level of detail (LOD) of the cartographic appearance and its accuracy at the same time. For digital models, coordinates of an object are stored separately in a database and must not be determined graphically on a map as before. It means that the values of accuracy and level of detail can not be proportional associated with each other any more. The accuracy of the generalized geometry is depending only on the transformation rules. The reduction of geometrical details by generalization can hardly be formalized and is only described by abstract operators (Forberg, June 2007; Hake et al., 2002; Sester, 2000). As a consequence, every individual algorithm presents its own interpretation of those procedures and offers a subjective implementation of the simplification task. However, neither of the existing methods gives any quality information about their generalized models.

There is a limited amount of papers dealing with the quality evaluation of cartographic generalization. In particular existing quality evaluation approaches consider the simplification of separate objects only as a part of the generalization process, but individual aspects of geometric deformations are not considered. In this paper, the change of accuracy of an object that is caused by generalization will be discussed profoundly. As our example data set, we use building ground plans provided by the city surveying office of Stuttgart that have been generalized by the algorithm described in (Kada, 2007).

According to the structure of the paper, the basic tendencies in the field of quality evaluation of map generalization in the literature will be presented in the next section. The third section presents characteristics, which will be used for comparing the geometrical similarity of the initial and simplified ground plan polygons. The final outcome resulting from the application of these characteristics for the quality analysis will be discussed in the fourth section. The next part proposes the similarity measure function for the purpose of comparing the appearance of two ground plan polygons. The last section gives a summary of the presented work and outlines further potential concepts of the research.

2. RELATED WORK

The task of quality evaluation of generalization is quite similar to the problem of measuring the similarity of objects in image processing. These similarity measures are used for the automation of such processes as object recognition or content-based search and retrieval of objects from graphic databases. Quality assessment is also needed to identify differences between objects. Though now, the main objective point of processing is not to determine how similar objects look like, but how good a generalized model is or which generalization algorithm better suits. The similarity of objects can be measured on the basis of the comparison of different geometric properties, called descriptors or form features, and their combinations. Two main trends, which are used to describe the appearance of

objects, can be distinguished in the literature. Boundary-based approaches only concern the outline of an object. For example, the contour of an object can be associated with a periodic function and identified by Fourier descriptors, which are coefficients of this function (Ballard and Brown, 1982; Gonzalez and Woods, 2002). Alternatively, the outline of an object can be described by the gradient of its edges along the perimeter using the turning function also known as tangent function (Frank and Ester, 2006; Latecki et al., 2003; Schlüter, 2001). Thus, the comparison of two objects can be implemented by defining a minimal distance between their turning functions. Another possibility of comparing two objects, is to measure the Hausdorff distance, which represents the largest deviation between two contours (Devillers and Jeansoulin, 2006; Schlüter, 2001).

A region-based approach considers an object as a whole. The object characteristics are identified as simple geometrical properties and can be evaluated from the moment-invariants. To be more detailed, among them are area, eccentricity and orientation of an object. The central moments can also be statistical interpreted as centroid, variance and skewness of a region (Ballard and Brown, 1982; Hild, 2003). Symmetric difference defines the non-overlaid area between two objects. This concept derived from the set theory presents deviations in spatial extension of two regions (Schlüter, 2001). Shape-based approaches result from the combination of the two abovementioned concepts. In (Werff and Meer, 2008), convexity, roundness and compactness are used for morphological classification of water bodies and evaluated from the perimeter and area of an object and of its convex hull.

Nevertheless, it is very difficult to calculate the similarity of objects only by comparing each characteristic separately. Therefore, methods for the aggregation of heterogeneous characteristics are needed. One possible solution of this task is the use of a weighted sum (Frank and Ester, 2006; Podolskaya et al., 2007). The weight of every characteristic reflects its importance for a given purpose. The description of an object by a single value makes the comparison easy. The generation of a feature vector composed of various object characteristics is another integration alternative. Two feature vectors can be compared with a distance function. A theoretic background of similarity measures in feature vector space is given in (Eidenberger, 2000; Hild, 2003; Steffens, 2007). Further research concerns different distance functions from various fields of science for the comparison of media objects identified by MPEG-7 descriptions (Eidenberger, 2006).

The quality evaluation of cartographic generalization for whole maps is described in (Bard and Ruas, 2004). They distinguish between three processing levels. "The evaluation for editing" is only used to reveal errors and mistakes after generalization. The next level is "the descriptive evaluation", which provides qualitative analysis of the deviation of the simplified objects from their references by means of different characteristics. Finally, "the evaluation for marking" represents the quality of generalization as a single value aggregating the outcomes of the previous level. The comparison of such synthetic characteristics allows answering the question of which alternative generalization is better for a certain purpose. The subject of the qualitative analysis is also differentiated, and stages of evaluation are classified as "micro", "meso" and "macro" levels. According to this bottom-up approach, the processing occurs at the level of a single object, group of objects or the whole data set. For the computation of the quality of generalization, different evolution functions can be chosen. Due to these

functions, the initial characteristic values of the original object before its modification can be propagated with respect to certain geometrical constraints. The evaluated values are further considered as the ideal characteristics after generalization. The deviation between such probable value and the actual outcome defines the quality of generalization. In support of uniformity and comprehension of the results a special interpretation function qualifies them according to four quality groups: "good", "rather good", "rather bad" and "bad".

Another concept of quality assessment of generalized maps is suggested in (Frank and Ester, 2006). In this work, the process of quality analysis is identified as a similarity measure between the initial and generalized cartographic appearance. Like in the previous work, it is also decomposed into three levels, which are nevertheless very different in their meaning. At the most detailed level called "Shape Similarity" the amount of changes between the outlines of the ground plan polygon before and after generalization will be evaluated by the comparison of their turning functions. The evaluation at the levels of "Location Similarity" and "Semantic Content Similarity" is based on Voronoi cells. Thereby, change in location of an object is reckoned relative to its direct neighbors. Semantic content depends not only on the amount of objects of each class as usually, but also on their spatial distribution. The approach proposed in (Podolskaya et al., 2007) is especially intended for the quality assessment of polygon generalization. Initial and generalized ground plan polygons are compared by their turning functions, areas, perimeters and number of vertices. A comparison of the integrated values provides the basis for the quality evaluation of generalized building and land cover polygons.

3. ESTIMATION OF GEOMETRIC DISTORTIONS CAUSED BY GENERALISATION

Because of the generalization, various geometrical distortions can be observed in the resulting object. Individual line segments might be displaced in different directions when compared to the initial ground plan. Also, the number of points and lines could be reduced, so it is hard to determine the unique correspondence between the geometric primitives of the basis and generalized object. But even without having knowledge about the procedural method of the simplification algorithm, the following characteristics can be used for measuring the similarity between two objects.

One possibility is to identify the differences between two objects directly by means of the Hausdorff distance or the intersection area. Another solution consists of two steps. In a first step, objects must be described by different characteristics. Then, these characteristics can be aggregated to a single value or a feature vector which can be compared in feature space with a distance function.

This section explains the meaning of each characteristic in the context of quality evaluation of generalization and presents their geometric interpretations to illustrate the mechanisms of the comparison of initial and modified polygons.

3.1 Hausdorff distance

Considering the contour of a ground plan polygon as a set of points, two objects can be compared by means of the shortest distance of their points. The maximum reflects the largest deviation of the generalized ground plan compared to its

original shape. This characteristic, also known as the Hausdorff distance, depends on the direction of calculation and must be evaluated for two objects mutually.

Concerning ground plan generalization, this value can be particularly important for checking whether an enhancement operator was needed. Being larger than the minimal generalization distance (the smallest visualized distance), the Hausdorff distance indicates that an essential part of the ground plan is missing. To this case belong typically elements of the contour which are considerably long, but their width is smaller than a generalization threshold. An example presented in figure 1 shows an important part of a ground plan that was completely removed in spite of its relative large area.



Figure 1. Hausdorff distance between the initial and generalized polygons

The width of the removed element is 2m, whereas the generalization threshold is 3m. The Hausdorff distance of 5m indicates that there is a significant part of the ground plan missing.

3.2 Overlapping and symmetric difference

Changes in the geometry of polygons can not only be considered as a displacement of line segments, but also as a change of their area extension. First of all, the change of the total size of a ground plan polygon can be determined as an area ratio of the generalized and initial objects (Podolskaya et al., 2007). But this value will not take into account the general displacement of an object. From this aspect, geometrical modifications can be described by the space that both objects occupy. The common area is the area where the two polygons overlap. The rest of the original and generalized objects consist of intrusions and extrusions accordingly and represent the symmetric difference.

The most adequate expression for these values is a percentage relation to the area of the original object. It is necessary to pay attention to the fulfillment of the following conditions. The overlapping area of the initial and generalized polygons should be as large as possible so that intrusions and extrusions are small (the first line of the equation 1). It is also preferable that extrusions compensate intrusions for the reason to keep the area of the object equal before and after modification (the second line of the equation 1). Practically, these requirements can be implemented with the symmetric difference which reflects the whole amount of extensional changes. The difference between intrusion and extrusion identifies how good these values are equalized (see the equation 1).

$$\begin{cases} SD = I(O) + E(O) \\ AD = |A(G) - A(O)| = |I(O) - E(O)| \end{cases} \quad (1)$$

where SD, AD – symmetric and area difference between the original and generalized polygons

I(O), E(O) – intrusion and extrusion relative to the area of the original object

A(O), A(G) – area of the original and generalized objects

3.3 Moment-Invariants

Moment invariants, or the functions that utilize them, are known in various fields of science such as physics, mathematics or computer vision. They can be identified as certain weighted averages and are very suitable in order to obtain many important object properties. From a classical statistics point of view, the n-th moment of a probability density function represents the expected value to the power of n of a randomly distributed variable. However, in image processing, the intensity of an image is taken instead of the probability function. Then, the area of an object can be considered as a two-dimensional distribution function where two random variables are coordinates of a set of points that compose this region. In this case, a moment of a certain order can be calculated as a double integral of multiplied coordinates raised to an appropriate power and weighted by the value of the intensity function in this point. Binary images, which are raster data as well, facilitate the task of the moment evaluation. Under these circumstances, the density function is equal to 1 inside the objects including its boundary, and 0 outside of it.

Considering every object as an entirety of pixels, it is convenient to deal with regions for the moment computation. But the ground plan polygons used in this work are represented by their contours stored as the sets of vertices. Thus, each ground plan can be considered as a region in the xy-plane bounded by the closed curve of its outline. To evaluate moments for such kind of data, Green's theorem was implemented. It allows for solving the double integral over the region as a line integral around a simple closed curve of its boundary. The moments obtained in this way are called the geometric moments about zero or also raw moments. They are necessary to derive such important properties of an object as its area from the 0-th order moment or the coordinates of the centroid as the ratio between the moments of the 1-th and the 0-th order. The moments calculated about the centroid are known as central moments. They are translation invariant and very useful for a statistical description of a region. Figure 2 represents the variances of an original and generalized polygon about their centroids calculated from the 2-d central moments.

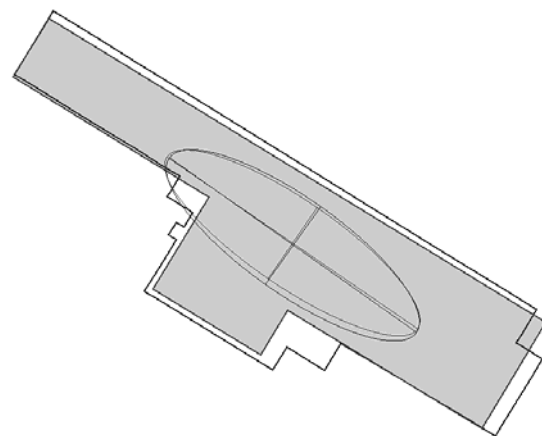

Figure 2. Geometric interpretation of the 2 central moments

4. AGGREGATION OF QUALITY CHARACTERISTICS

The degree of similarity of the appearance of two objects can be determined by comparing certain geometrical characteristics. Each of these characteristics will be affected differently by the simplification, depending on the used algorithm. The changes of such values taken separately will only offer the particular aspects of the transformation influence. For the purpose to reflect the total effect of the algorithm and to evaluate its quality, the different characteristics of an object must be compared as a whole. But often it is difficult to aggregate heterogeneous characteristics by a generic value. For this reason, selected object characteristics span a multidimensional feature space. Every characteristic of an object with its individual metric represents one axis of this space. Thus, each object can be described as a feature-vector whose elements are a numeric representation of certain characteristics.

Various characteristics can be used for generating the feature-vector. If the objects are considered as regions, they can be represented, for example, by their central moments. In this case, the feature-vector will express the area of the object, variance and skew or asymmetry with regard to the centroid of this region. As characteristic elements of a vector, the basic geometrical properties such as elongation of an object or its orientation can be alternatively applied. Such feature-vectors are translation invariant and can be especially useful when an object displacement takes place. For an estimation of the similarity of two feature-vectors, different distance functions can be used. For example the quasi-Euclidean distance (equations 2 and 3) which is a particular form of the Minkowski-distance:

$$D(C(O), C(G)) = \begin{cases} 0 & C(O) = C(G) \\ \left| \frac{C(O)}{C(G)} - 1 \right| & |C(O)| < |C(G)| \\ \left| \frac{C(G)}{C(O)} - 1 \right| & |C(G)| < |C(O)| \end{cases} \quad (2)$$

where $C(O), C(G)$ – a certain characteristic of the original and generalized polygon
 $D(C(O), C(G))$ – distance between a characteristic of the original and generalized polygon

$$D(O, G) = \sqrt{\sum_{i=1}^n D(C(O), C(G))^2} \quad (3)$$

where $D(O, G)$ – quasi-Euclidean distance between all characteristics of the original and generalized polygon

5. RESULTS AND DISCUSSION

The described quality characteristics were used to compare original and generalized ground plans which were computed automatically with the approach presented in (Kada, 2007). This approach generates simplified versions of 3D building models. However, only the ground plans were considered for the quality evaluation. As the algorithm tries to fit the new model in 3D,

the generalized ground plans are expected to match not optimal to the original ground plan. This makes them to a perfect test data set for our studies. To obtain ground plans that fit better to its original geometry, (Peter et al., 2008) applied a least-squares adjustment. Therefore, our test data sets consist of three ground plans: original, generalized and adjusted which are represented in table 1.

The results of the qualitative analysis, which is based on the characteristics presented in the sections 3.1-3.2, are presented in table 2. Smaller values mean less change when comparing the generalized shape to its original. It can be seen that all ground plan polygons have been improved by the adjustment process.

The extended difference is an aggregated value and is calculated as an average value of the symmetric and area difference. However, it is possible to prioritize any of these characteristics giving them different weights. With regard to the extended difference, the original generalization of the Opera House and the New Palace are rather good. Therefore, the post-processing step could only slightly enhance the result. Only the generalization of the Hindenburgbau shows a large extended difference which is the result of large intrusion areas. The adjustment increases the lower part of the ground plan and thus decreases considerably the intrusion.

The evaluation of the Hausdorff distance leads to different results. The adjustment method, suggested in (Peter et al., 2008) is intended for finding the main lines of the original object. The importance of each line is defined by the aggregated length of the original ground plan segments it covers. As a result of such correction, several parts of the modified polygon can move away from the original contours. The difference between these two outlines can get very large, as for example by the Opera House and New Palace. Concerning the New Palace, the threshold of 10m was even exceeded because of the large element missing in the central part of the ground plan. The adjustment method can only correct the contour of an existing polygon, but not change the number of vertices.

6. CONCLUSION

In this paper, different characteristics for the quality evaluation of generalization algorithms were discussed. Qualitative analysis represents the key task if it is necessary to choose between alternative generalization results. For this reason, two main approaches were discussed: boundary-based and region-based. The boundary-based approach was implemented based on the Hausdorff distance, which can be compared with the minimal generalization distance. A larger value than the minimal generalization distance can indicate that essential parts of the building have been omitted. These parts should be enhanced rather than removed. The boundary-based approach defines area changes of the original object by the percentage of intrusions and extrusions. For the quality of generalization it is important that these characteristics are as small as possible and compensate each other. In order to consider these two conditions together, they were aggregated to the “extended difference”.

This approach was tested with two sets of generalization results. One set was derived from the 3D generalization algorithm described in (Kada, 2007). The other data set is the same as the first one, but adjusted to the original ground plan geometry (Peter et al., 2008). According to the extended difference, the adjustment improved the generalization results. But this correction had a negative effect on the Hausdorff distance.

The characteristics applied for the quality analysis of generalization in this work are not the only way to compare the original and generalized ground plan polygons. In (Hake et al., 2002) alternative constraints, which generalization can fulfill, were mentioned. Generalized objects can be true to shape, location or extend. All quality characteristics can not be preserved at the same time. Trueness to the ground plan can be calculated as a sum of line segments of the original model

overlapped by the generalized ground plan. Change of location of the modified object can be identified by displacement of its centroid. Such simple geometrical properties as orientation of the object or its elongation derived from central moments can be also used to compare the original and generalized polygons. These different types of analysis will be subject of further research.

Generalization algorithm	1	2	3
Generalization threshold, m	10,0	5,0	10,0
Kada 2007			
Peter 2008			

Table 1. Original and generalized ground plan polygons

Characteristic	1 (Hindenburgbau)		2 (Opera House)		3 (New Palace)	
	Kada 2007	Peter 2008	Kada 2007	Peter 2008	Kada 2007	Peter 2008
Area:						
– original, m ²	3975,086	3975,086	4549,747	4549,747	7676,598	7676,598
– generalized, m ²	3481,075	3919,162	4691,084	4644,688	7421,708	7478,984
Intrusion						
– m ²	550,985	123,162	31,238	31,448	497,441	382,191
– %	13,86	3,10	0,69	0,69	6,48	5,11
Extrusion						
– m ²	56,974	67,234	172,575	126,389	242,550	194,576
– %	1,43	1,69	3,79	2,78	3,16	2,53
Symmetric difference,%	15,29	4,79	4,48	3,47	9,64	7,64
Area difference, %	12,43	1,41	3,1	2,09	3,32	2,58
Extended difference	13,86	3,10	3,79	2,78	6,48	5,11
Hausdorff distance, m	8,521	7,360	4,316	5,586	10,649	10,650

Table 2. Comparison of the quality characteristics of two generalization alternatives

REFERENCE

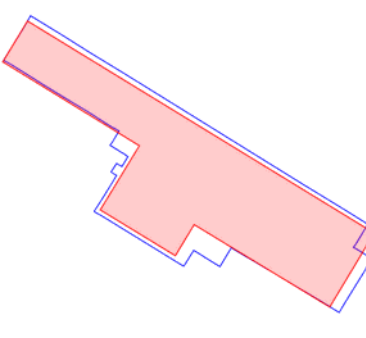
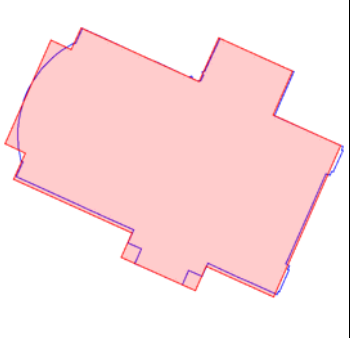
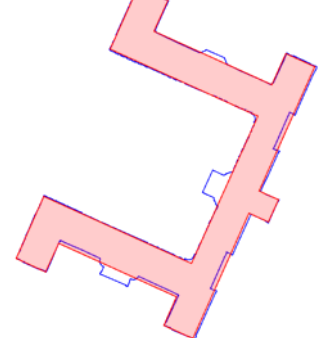
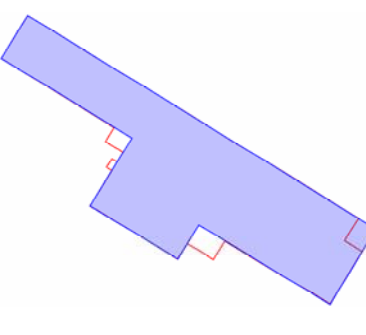
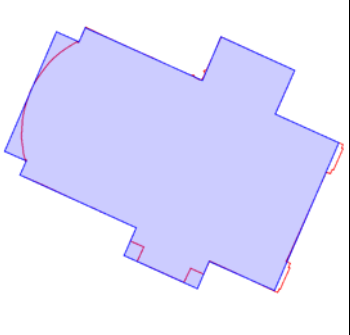
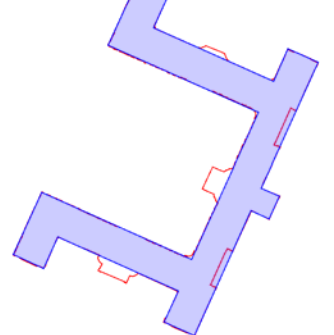
- Ballard, D.H. and Brown, C.M., 1982. *Computer Vision*. Prentice-Hall, London, 523 pp.
- Bard, S. and Ruas, A., 2004. Why and How Evaluating Generalised Data?, *Proceedings of the 11th International Symposium on Progress in Spatial Data Handling*. Springer, pp. 327-342.
- Cheng, T., 2001. Quality Assessment of Model-Oriented Generalization, 4th Workshop on Progress in Automated Map Generalization, Beijing, China.
- Dettori, G. and Puppo, E., 1998. Designing a library to support model-oriented generalization, *Proceedings of the 6th ACM international symposium on Advances in geographic information systems*. Washington, D.C., United States, pp. 34 - 39.
- Devillers, R. and Jeansoulin, R. (Editors), 2006. *Fundamentals of Spatial Data Quality*. Geographical Information Systems Series. ISTE Ltd.
- Eidenberger, H., 2000. *Suchmodellbasiertes Content-based Image Retrieval. Ähnlichkeitsdefinition, Anwendung und Automatisierung*. Dissertation Thesis, Universität Wien, Wien.
- Eidenberger, H., 2006. Evaluation and Analysis of Similarity Measures for Content-based Visual Information Retrieval. *ACM Multimedia Systems Journal*, 12(2): 71-87.
- Forberg, A., June 2007. Generalization of 3D Building Data Based on a Scale-Space Approach. *ISPRS Journal of Photogrammetry and Remote Sensing*, 62(2): 104-111.
- Frank, R. and Ester, M., 2006. A Quantitative Similarity Measure for Maps, *Proceedings of 12th International Symposium. Progress in Spatial Data Handling*. Springer, pp. 435-150.
- Gonzalez, R.C. and Woods, R.E., 2002. *Digital Image Processing*. Prentice Hall.
- Hake, G., Grünreich, D. and Meng, L., 2002. *Kartographie*. Walter de Gruyter Verlag, Berlin, 604 pp.
- Han-Sze-Chuen, D., Mustière, S. and Moulin, B., 2002. Formalising the Geographic Database Generalisation Process by Means of a Conflicts/Operations Graph, *Proceedings of the Symposium on Geospatial Theory, Processing and Applications*, Ottawa, Canada.
- Hild, H., 2003. *Automatische Georeferenzierung von Fernerkundungsdaten*. Dissertation Thesis, Universität Stuttgart, Stuttgart.
- Kada, M., 2007. Scale-Dependent Simplification of 3D Building Models Based on Cell Decomposition and Primitive Instancing, *Proceedings of the International Conference on Spatial Information Theory: COSIT '07*, Melbourne, Australia.
- Latecki, L.J., Lakämper, R. and Wolter, D., 2003. Shape Similarity and Visual Parts. In: I. Nyström, G.S. Baja and S. Svensson (Editors), *11th International Conference on Discrete Geometry for Computer Imagery*. Springer, Naples, Italy, pp. 34-51.
- Peter, M., Haala, N. and Fritsch, D., 2008. Preserving Ground Plan and Facade Lines for 3D Building Generalization, *Proceedings of the XXIst Congress of the ISPRS*, Beijing, China.
- Podolskaya, E.S., Anders, K.-H., J.-H. Haurert and Serester, M., 2007. Quality Assessment for Polygon Generalization, 5th International Symposium on Spatial Data Quality (SDQ 2007), ITC, Enschede, The Netherlands.
- Schlüter, D., 2001. Hierarchisches Perzeptives Gruppieren mit Integration dualer Bildbeschreibungen, Bielefeld, pp. 222.
- Sester, M., 2000. *Maßstabsabhängige Darstellungen in Digitalen Räumlichen Datenbeständen*. Professorial Dissertation Thesis, Universität Stuttgart, Stuttgart.
- Steffens, T., 2007. *Enhancing Similarity Measures with Imperfect Rule-Based Background Knowledge*. IOS Press, Amsterdam, The Netherlands, 244 pp.
- Werff, H.M.A.v.d. and Meer, F.D.v.d., 2008. Shape-Based Classification of Spectrally Identical Objects. *ISPRS Journal of Photogrammetry and Remote Sensing*, 63(2).